

# Full-scale modelling of food industry WWTP: Model evaluation and reuse

Mathieu Goudeseune<sup>1</sup>, Andy Vandekerckhove<sup>2</sup>, Wim Moerman<sup>3</sup> and Stijn WH van Hulle<sup>1\*</sup>

<sup>1</sup>Research group EnBiChem, Department of Industrial Engineering and Technology, University College West-Flanders, Graaf Karel de Goedelaan 5, B-8500 Kortrijk, Belgium

<sup>2</sup>Akwadok BVBA, Hoekstraat 3, B-8540 Deerlijk, Belgium

<sup>3</sup>Clarebout Potatoes NV., Heirweg 26, B-8950 Heuvelland, Belgium

## Abstract

This study aimed at testing a mathematical model for an industrial WWTP. This model was developed in a previous study. The characterisation of the influent wastewater was repeated and results revealed that the composition of the wastewater was somewhat changed compared to the previous study. In order to account for varying wastewater composition in the future, the influence of this composition on the effluent concentration was calculated based on relative sensitivity functions. This calculation revealed that the effluent COD concentration is most affected by the inert COD fraction in the influent and that the effluent ammonium concentration is most affected by the biodegradable COD fraction in the influent. As such experimental efforts can be conducted towards determination of the fraction that is most influential on the required result. The model was further evaluated with new data. It could be shown that agreement between simulated and measured data was very good and that no model recalibration or extension will be necessary. As such the industrial WWTP model passed the model evaluation test. In the future this model will be used for potential further upgrades.

**Keywords:** food industry WWTP, ASM, model evaluation and reuse, optimisation

## Nomenclature

ASM	Activated sludge model
BOD	Biological oxygen demand (mgBOD/l)
DO	Dissolved oxygen concentration (mg O <sub>2</sub> /l)
COD	Chemical oxygen demand (mgCOD/l)
MLVSS	Mixed liquor volatile suspended solids
RSF	Relative sensitivity functions
S <sub>s</sub>	Biodegradable and soluble COD (mgCOD/l)
S <sub>i</sub>	Non-biodegradable and soluble COD (mgCOD/l)
TIC	Theil's inequality coefficient
TSS	Total suspended solids
WWTP	Wastewater treatment plant
X <sub>s</sub>	Slowly biodegradable COD (mgCOD/l)
X <sub>i</sub>	Non-biodegradable and particulate COD (mgCOD/l)
y <sub>i</sub>	Simulated data points
y <sub>i,m</sub>	Measured data points

## Introduction

Several studies, both theoretical and experimental, have already proven that mathematical modelling of wastewater treatment processes is an elegant and cost-effective tool to study and optimise these treatment processes. Modelling offers the possibility to investigate certain engineering questions without time-consuming and expensive laboratory tests. In the last 30 years relatively reliable dynamic simulation models for the activated sludge process, including biological N and/or P removal (e.g. Dold et al., 1980; Wentzel et al., 1992; Henze et al., 1987,

2000) have been developed (Wentzel et al., 2006). The increase in calculation capacity of the personal computer has led to an exponential increase in the number of activated sludge model case studies.

Stricker and Racault (2005), for example, used a WWTP model to optimise an aerobic biological treatment system for winery effluents. Choubert et al. (2006) evaluated two operating strategies of activated sludge systems to cope with the increase in the carbon and nitrogen loading rates generally observed on wastewater treatment plants located in winter resorts. Brdjanovic et al. (2000) used a model for better understanding of full-scale biological phosphorus removal. Salem et al. (2002) evaluated different alternatives for the upgrade of a biological nitrogen removal plant with a model. Horan and Chen (1998) used an ASM1 model (Henze et al., 2000) to optimise a full-scale activated sludge plant, treating a high-strength pulp and paper mill effluent. Artan et al. (2002) assessed the performance of sequencing batch reactors for simultaneous nitrogen and phosphorus removal is evaluated by means of model simulations using the ASM2d activated sludge model (Henze et al., 2000).

Most of these studies, including most of our own work (see for example Van Hulle and Vanrolleghem (2004) and Van Hulle et al. (2006)), develop a wastewater treatment plant (WWTP) model and use this model for scenario analysis in view of a process upgrade. The development of such a model includes plant data collection, model calibration and model validation. In most cases this validated model is used for simulation of different scenarios and consequently the 'optimal' scenario is implemented in the real plant.

However, very rarely the outcome of this optimal scenario is compared to experimental results obtained with the optimised plant. Sin et al. (2004) used a systematic modelling approach to determine the optimal operation strategy for nitrogen (N) and phosphorus (P) removal of sequencing batch reactors (SBRs)

\* To whom all correspondence should be addressed.

☎ +32 56 241237; fax: +32 56 241224;

e-mail: [Stijn.Van.Hulle@Howest.be](mailto:Stijn.Van.Hulle@Howest.be)

Received 31 July 2007; accepted in revised form 29 November 2007.

and applied this strategy successfully to a lab-scale SBR. The model predicted that it was possible to improve/increase the current performance of the SBR system by around 54% and 74% for N and P removal respectively. Experimental evaluation of this prediction showed an improvement of total nitrogen removal and phosphorous removal of 53% and 43% respectively (Sin et al., 2006). However, long-term stable performance could not be achieved due to a severe filamentous bulking problem induced by the optimal operation conditions. Comparing the model results used for the SBR optimisation with the experimental results further falsified the model. As such the model needed to be extended and recalibrated for further use.

In the case study presented here, it was shown that a model of a full-scale industrial WWTP, which was developed previously for model based optimisation and upgrade (Vandekerckhove et al., 2007), could predict the behaviour of a (partially) upgraded plant without needing additional model development and/or calibration. The model was further used for evaluation of different upgrade options.

## Methods

### Description of the WWTP

The food industry WWTP treats on average 1 550 m<sup>3</sup> of wastewater coming from the production facility per day (Vandekerckhove et al., 2007). This wastewater is highly loaded with COD and ammonium. The COD content of the wastewater is mainly removed in an anaerobic UASB reactor, to which the wastewater is first sent after pretreatment (oil and grease skimmer, lamellar settling and flotation). After treatment in the UASB reactor the wastewater is sent to the aerobic part of the WWTP. This stream will further be denoted as the direct stream. A bypass exists to make sure that wastewater can be sent directly to the aerobic part of the WWTP after pretreatment. This stream is identical to the stream that is sent to the UASB reactor and will further be denoted as the bypass stream. In the initial operation schedule (before the upgrade), on average 50 m<sup>3</sup>/d is bypassed. During the experimental period of the study presented here, the bypass flow was not applied.

Both streams, i.e. the direct stream and the bypass stream, are mixed before entering the aerobic part of the WWTP. This aerobic part of the WWTP consisted, before the upgrade, of 2 parallel trains. The first train consist of 2 anoxic reactors, with a respective volume of 600 and 1 000 m<sup>3</sup>, put in series before an aerobic reactor with a volume of 3 100 m<sup>3</sup>. This aerobic reactor is operated with intermittent aeration: the aeration is

switched on for 5 h and the DO is controlled at 3 mgO<sub>2</sub>/ℓ after which the aeration is switched off for 5 h. Before the upgrade, about 40% of the influent flow was treated in this train. The second train consists of 1 anoxic reactor and 1 aerobic reactor, with respective volumes of 541 m<sup>3</sup> and 2 700 m<sup>3</sup>. About 60% of the flow was treated in this train. In both trains an internal circulation exists from the aerobic reactor to the first anoxic reactor. The flow rate of this internal recycle is, respectively, 400 m<sup>3</sup>/h for the first train and 250 m<sup>3</sup>/h for the second train.

After the aerobic part of the WWTP the wastewater is sent to a secondary clarifier. The underflow flow rate of the settler is equal to 100 m<sup>3</sup>/h and on average about 10 m<sup>3</sup>/h of sludge is wasted. The effluent of this clarifier is partly discharged after tertiary treatment and partly reused in the production facility. In this tertiary treatment flocculant and coagulant is dosed to the waste stream after which the stream is sent to an additional settler. The purpose of this tertiary treatment is the removal of phosphate and the further reduction of effluent COD.

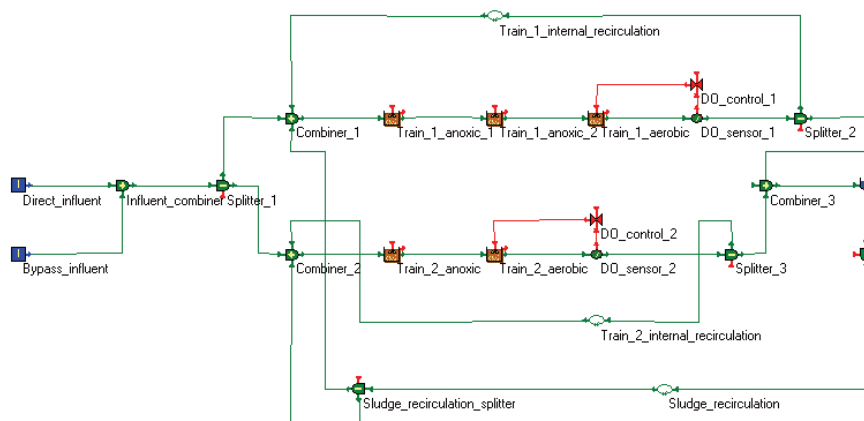
The initial WWTP lay-out (before the upgrade) as implemented graphically in the modelling and simulation environment WEST<sup>®</sup> (Vanhooren et al., 2003) is shown in Fig. 1.

The WWTP upgrade aims at increasing the WWTP capacity and treatment efficiency. The following modifications were planned. First, the 2 anoxic tanks of Train 1 are combined to 1 reactor with a volume of 1 600 m<sup>3</sup>. Second, the volume of the aerobic tank in train 1 is increased to 3 600 m<sup>3</sup>. Third, the recycle flow rate in Train 1 is increased from 400 m<sup>3</sup>/h to 1 400 m<sup>3</sup>/h. Fourth, the water coming from Train 1 and Train 2 is sent to an additional anoxic tank with a volume of 400 m<sup>3</sup> and an additional aerobic tank with a volume of 200 m<sup>3</sup> in which the DO is controlled at 3 mgO<sub>2</sub>/ℓ. The goal of installing this additional volume was to provide additional capacity for nitrification and denitrification in this so-called post denitrification in order to increase ammonium and nitrate removal.

Train 2 is left unchanged. The graphical implementation of the upgraded WWTP in the modelling and simulation environment WEST<sup>®</sup> is shown in Fig. 2.

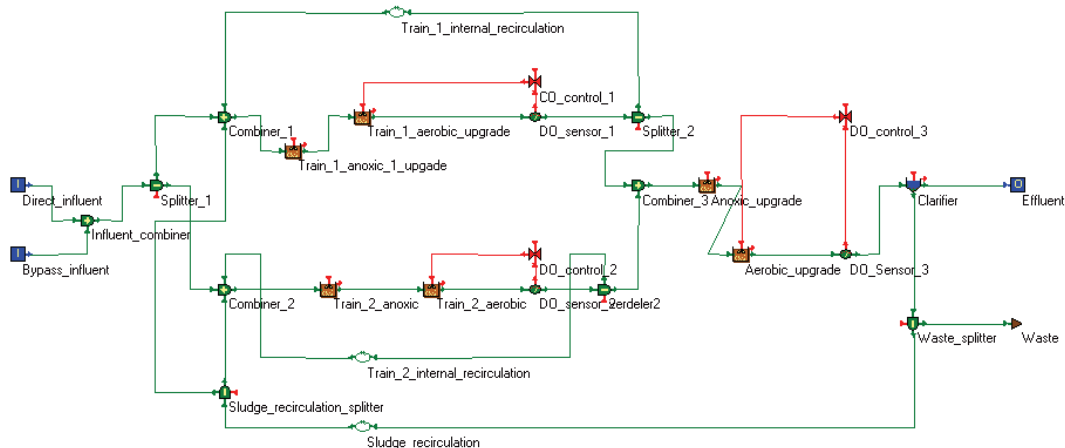
Model simulations by Vandekerckhove et al. (2007) revealed that with this lay-out up to 50% reduction of the total nitrogen concentration and up to 98% reduction of the ammonium concentration in the effluent can be obtained.

At the time of the study presented here, upgrade of the WWTP was fully going on. As such experimental results were obtained with an intermediate lay-out, which was also implemented in the modelling and simulation environment WEST<sup>®</sup> as presented in Fig. 3. The difference with the final upgraded WWTP is that the aerobic upgrade reactor is not

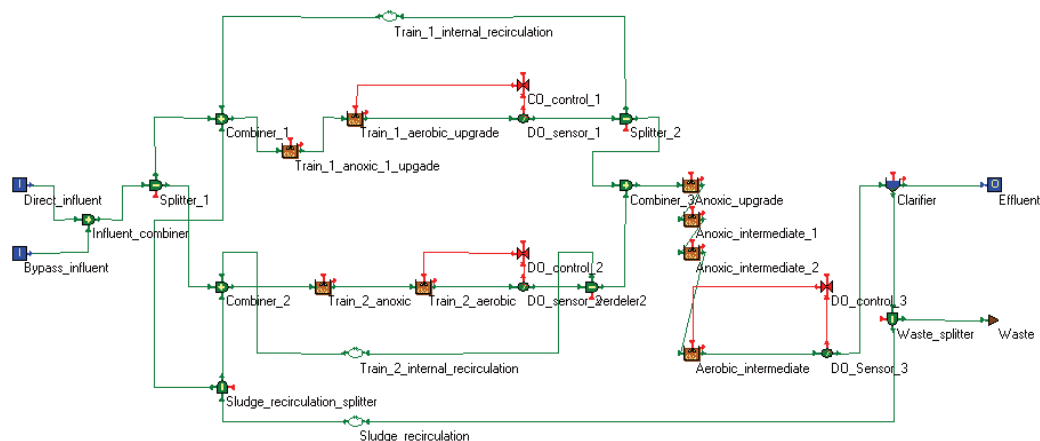


**Figure 1**  
The schematic initial lay-out of the WWTP under study as implemented in the modelling and simulation software WEST<sup>®</sup>

**Figure 2**  
The schematic lay-out of the upgraded WWTP as implemented in the modelling and simulation software WEST®



**Figure 3**  
The intermediate lay-out of the WWTP as implemented in the modelling and simulation software WEST®



yet installed and that available (spare) basins are used. After the anoxic upgrade reactor the wastewater is sent to 2 anoxic tanks, with a respective volume of 600 m<sup>3</sup> and 1 000 m<sup>3</sup> and to an aerobic tank with a volume of 3 100 m<sup>3</sup>. In this aerobic tank the DO concentration is controlled at 3 mgO<sub>2</sub>/ℓ.

### Mathematical modelling

The Activated Sludge Model No. 1 (ASM1, Henze et al., 2000) was chosen as the standard model for the description of bacterial growth and decay processes. The default values as proposed by Henze et al. (2000) were used for the different kinetic and stoichiometric parameters in the initial study presented by Vandekerckhove et al. (2007) as well as this study.

Temperature dependency of the biological reactions was not considered as the WWTP temperature does not vary significantly during the year because of the increased temperature of the wastewater coming from the production facility.

All the WWTP reactors were considered as completely mixed and are therefore modelled as completely stirred reactors (CSTR). An ideal point settler with a non-settleable fraction of the biomass ( $f_{ns}$ ) is considered as an appropriate model for the secondary settler, similar to the work of Van Hulle and Vanrolleghem (2004). The non-settleable fraction of the biomass ( $f_{ns}$ ) was set to 0.5%.

### Influent characterisation

A 5-month data set (May-October 2006) was made available by the plant operators for re-evaluation of the model. Influent flow rate, COD concentration and ammonium concentration are

depicted in Fig. 4. Only measured data from the direct stream are presented as no bypass flow was applied during the study. Several grab samples revealed that the influent nitrate concentration was also on average 2.9 mgN/ℓ, while no nitrite was detected. During the time of the study the plant was operated at a rather high sludge residence time of 34 d.

Influent characterisation was based on the method proposed by Roozeveld and van Loosdrecht (2001). This characterisation was conducted in a similar way and 1 year after the influent characterisation of Vandekerckhove et al. (2007). This characterisation aimed at dividing the total influent COD concentration into a biodegradable and soluble fraction ( $S_s$ ), a non-biodegradable and soluble fraction ( $S_p$ ), a slowly biodegradable fraction ( $X_s$ ) and a non-biodegradable and particulate fraction ( $X_p$ ). The characterisation was performed with grab samples and the influent COD during the characterisation period ranged between 4 and 8 gCOD/ℓ.

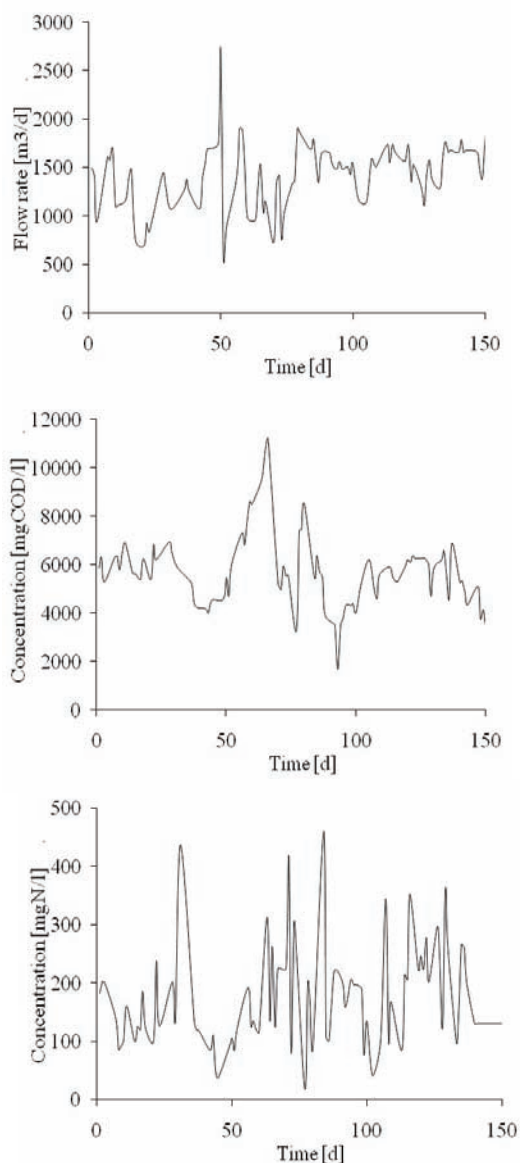
### Chemical analysis

COD concentration, BOD<sub>20</sub> concentration, suspended solids concentration, ammonium concentration, nitrate concentration and oxygen concentration were all analysed according to standard methods (*Standard Methods*, 1992).

### Results and discussion

#### Influent characteristics

Vandekerckhove et al. (2007) determined the COD fractions for both the direct stream and the bypass stream as presented in Table 1. In the same table results obtained in this study are presented.



**Figure 4**

The influent flow rate (top), the total influent COD concentration (middle) and the influent ammonium concentration (bottom) of the direct influent

TABLE 1 COD fractions for both the direct stream and the bypass stream expressed as a percentage of the total influent COD				
	Direct stream (%)		Bypass stream (%)	
	Vande-kerckhove et al. (2007)	This study	Vande-kerckhove et al. (2007)	This study
$S_s$	75	48	36	50
$S_i$	6	2	15	1
$X_s$	13	28	48	33
$X_i$	6	22	1	16

From this table it can be seen that the characteristics of the influent have changed somewhat. This is possibly due to the different operation of the anaerobic UASB and alterations in the production facility.

In order to assess the necessity of performing another influent characterisation in a further study, the influence of the different COD fractions on the effluent COD, ammonium and nitrate concentration was assessed based on relative sensitivity functions (RSF):

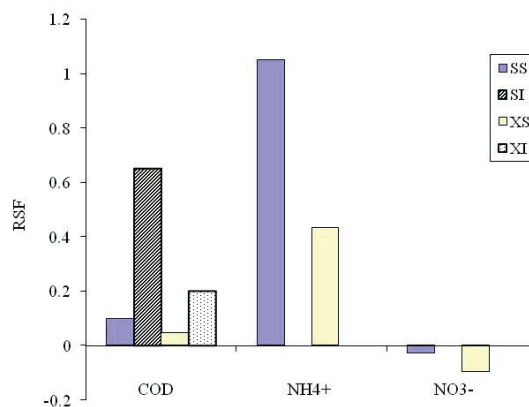
$$RSF = \frac{\partial C}{\partial f} \frac{f}{C}$$

where:

C is the effluent concentration (COD, ammonium or nitrate)

f is the influent COD fraction ( $S_s$ ,  $S_i$ ,  $X_s$ , or  $X_i$ )

The RSF functions were calculated numerically by central differences with a perturbation of the influent COD fractions with 0.1% (De Pauw and Vanrolleghem, 2006). Results of this sensitivity analysis are depicted in Fig. 5.



**Figure 5**

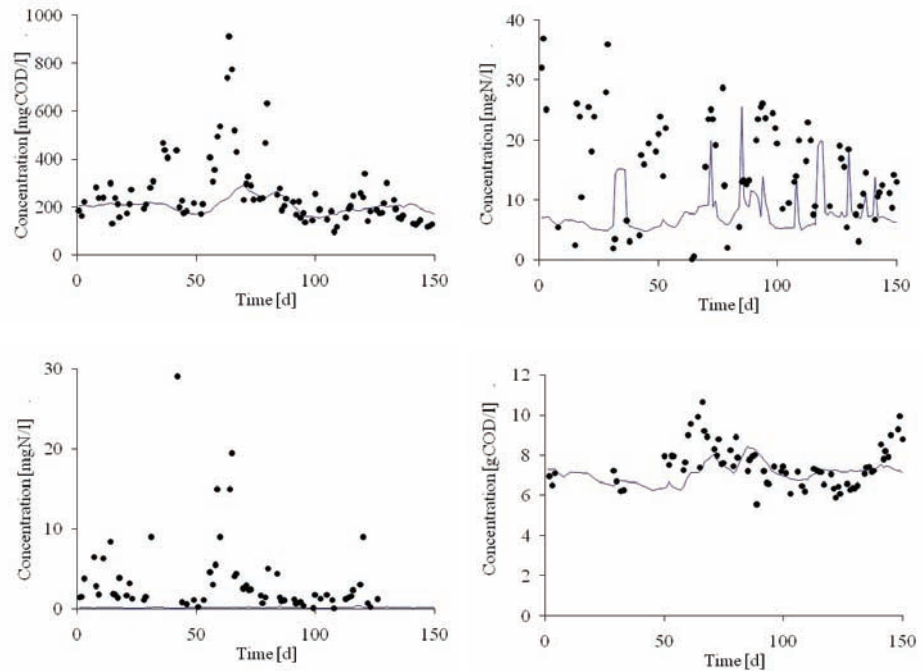
Relative sensitivity functions showing the dependence of the effluent COD, ammonium and nitrate concentration on the influent COD fractions

Figure 5 shows that the effluent COD concentration is most influenced by the  $S_i$  and  $X_i$  fractions in the influent, while ammonium is most influenced by the  $S_s$  and  $X_s$  fractions in the influent. This is due to the decreased availability of oxygen for ammonium oxidisers because of the increased consumption of oxygen by heterotrophic bacteria. Nitrate is not influenced strongly by an influent COD fraction as values of the RSF below 0.1 are not considered as very influential. From this figure it can be concluded that the experimental effort of determining an influent COD fraction strongly depends on the future goal of the modelling exercise, i.e. either improving COD or nitrogen removal.

### Simulation results

The results from the influent characterisation were used, in combination with the 5-month data set to simulate the behaviour of the intermediate lay-out of the WWTP. In Fig. 6, as an example, the comparison between measured and simulated soluble COD concentration, ammonium concentration, nitrate concentration and MLVSS concentration in the aerobic reactor of Train 2 is depicted. The simulated ammonium and nitrate concentrations could directly be extracted from the ASM1 model. The simulated soluble COD was calculated as being the sum of  $S_i$  and  $S_s$ , while the soluble COD concentration was determined as the COD concentration of a sample after filtration over a 0.45  $\mu\text{m}$  filter. The simulated MLVSS concentration was calculated as the sum of the particulate components considered in ASM1 divided by 1.5 according to Henze et al. (2001). The measured MLVSS concentration was calculated based on the TSS measurements:

**Figure 6**  
Comparison between measured (●) and simulated (-) soluble COD concentration (top left), nitrate concentration (top right), ammonium concentration (bottom left) and MLVSS concentration (bottom right) in the aerobic reactor of Train 2



an MLVSS/TSS ratio of 0.7 was assumed.

From this figure it can be seen that the agreement between measured and simulated soluble COD concentration and MLVSS concentration is good. Only the peak around day 60 was underestimated.

This peak is partially due to uncontrolled incidents which are very difficult to model (personal communication with the operators). A previous study (Van de Kerkhove et al., 2007) showed that controlled dynamic incidents can be captured by the model.

The ammonium concentration is also somewhat underestimated, but both simulated and measured data are low. The actual nitrate concentration in the WWTP varied considerably during the experimental period because of uncontrolled incidents. As such it was difficult to have a good agreement between measured and simulated data, although both data are in the same range.

In order to quantify the goodness of fit the Theil's inequality coefficient (TIC; Theil, 1961) was calculated. This TIC is defined with the following equation:

$$TIC = \frac{\sqrt{\sum_i (y_i - y_{m,i})^2}}{\sqrt{\sum_i y_i^2 + \sum_i y_{m,i}^2}}$$

where:

- $y_i$  represents the simulated data points
- $y_{i,m}$  represents the measured data points

A value of the TIC lower than 0.3 indicates a good agreement with measured data (Zhou, 1993).

First the TIC was calculated for the data presented in Fig. 6. A value of 0.28 was obtained. Second, the average COD, ammonium and nitrate data from the aerobic reactor of Train 2, the anoxic upgrade reactor, the aerobic intermediate reactor and the effluent were used for the calculation of the TIC. Based on these data the TIC was calculated to be 0.14. As such it can be concluded that the model developed by Vandekerckhove et al. (2007) passed the evaluation test and that the conclusions drawn concerning the upgrade of the WWTP will hold. No model recalibration or extension will be necessary.

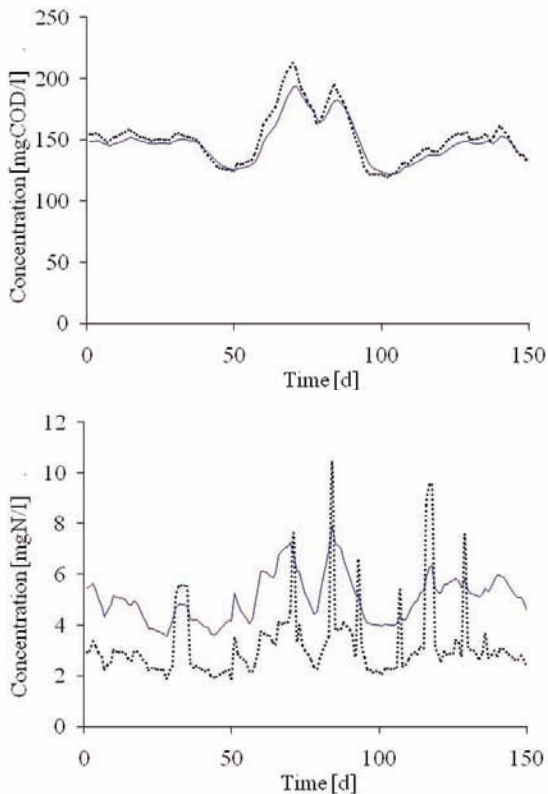
Finally, the difference in effluent concentrations between the intermediate and the upgraded WWTP was quantified by running a simulation with the upgraded WWTP lay-out and the influent data of the intermediate WWTP. Simulations showed that no significant improvement will be obtained for COD and ammonium concentrations. The major part of the improvements was already obtained when the initial lay-out was upgraded to the intermediate lay-out. The nitrate concentration on the other hand will further be reduced with an additional 40% from 5 mgN/l (on average) to 3 mgN/l (on average). This seems a small decrease in absolute numbers, but it should be remembered that the total nitrogen discharge limit is set to 15 mgN/l. This is illustrated in Fig. 7 (next page) where the simulated effluent total COD and nitrate concentration of the intermediate and the upgraded WWTP is depicted. It can be seen that effluent nitrate concentration is significantly lower for the upgraded WWTP, although the upgraded WWTP is more vulnerable for peaks of nitrate.

## Conclusions and perspectives

This study aimed at testing a mathematical model for an industrial WWTP. This model was developed in a previous study.

The characterisation of the influent wastewater was repeated. This characterisation revealed that the composition of the wastewater was somewhat altered compared to the previous study. In order to account for varying wastewater composition in the future, the influence of this composition on the effluent concentration was calculated based on relative sensitivity functions. This calculation revealed that the effluent COD concentration is most affected by the inert COD fraction in the influent and that the effluent ammonium concentration is most affected by the biodegradable COD fraction in the influent. As such experimental efforts can be focused on the determination of the fraction that has the highest impact on the required result.

The model was further evaluated with new data. It could be shown that agreement between simulated and measured data was very good and that the no model recalibration or extension will be necessary.



**Figure 7**

Comparison between simulated effluent total COD (top) and nitrate (bottom) concentration of the intermediate (-) and the upgraded WWTP (-)

As such the industrial WWTP model passed the model evaluation test. In future this model will be used for potential further upgrades, such as the construction of extra treatment volume as was demonstrated in this paper.

## Acknowledgements

The authors would like to thank Clarebout Potatoes NV for the fruitful cooperation, making the plant data available and performing additional measurements. The support of Y. Amerlinck and MostforWater N.V. (Kortrijk, Belgium, [www.mostforwater.com](http://www.mostforwater.com)) is greatly appreciated.

## References

- ARTAN N, WILDERER P, ORHON D, TASLI R and MORGENROTH E (2002) Model evaluation and optimisation of nutrient removal potential for sequencing batch reactors. *Water SA* **28** 423-432.
- BRDJANOVIC D, VAN LOOSDRECHT MCM, VERSTEEG P, HOOIJMANS CM, ALAERTS GJ and HEIJNEN JJ (2000) Modelling COD, N and P removal in a full-scale WWTP Haarlem Waarderpolder. *Water Res.* **34** 846-858.
- CHOUBERT J-M, RACAULT Y, GRASMICK A, CANLER J-P and HEDUIT A (2006) A simulation-based optimisation approach to control nitrogen discharge by activated sludge under winter seasonal peak load. *Water SA* **32** 561-566.
- DE PAUW DJW and VANROLLEGHEM PA (2006) Practical aspects of sensitivity function approximation for dynamic models. *Math. Comp. Modell. of Dyn. Sys.* **12** 395-414.
- DOLD PL, EKAMA GA and MARAIS GvR (1980) A general model for the activate sludge process. *Prog. Water Technol.* **12** (Tor) 47-77.
- HENZE M, HARREMOES P, LACOUR JANSEN J and ARVIN E (2001) *Wastewater Treatment. Biological And Chemical Processes (3rd rev. edn.)*. Springer-Verlag Berlin And Heidelberg GmbH & Co. Kg (Germany).
- HENZE M, GRADY CPL (Jr), GUJER W, MARAIS GvR and MATSUO T (1987) *Activated Sludge Model No 1, IWA Scientific and Technical Report No 1*, IWA London. ISSN 1010-707X. 33 pp.
- HENZE M, GUJER W, MATSUO T and VAN LOOSDRECHT MCM (2000) *Activated Sludge Models ASM1, ASM2, ASM2d and ASM3*. Scientific and Technical Reports. IWA publishing, London, UK.
- HORAN NJ and CHEN W (1998) The treatment of a high strength pulp and paper mill effluent for waste water re-use (I): The use of modelling to optimise effluent quality from the existing wastewater treatment plant. *Environ. Tech.* **19** (2) 153-161.
- ROELEVELD PJ and VAN LOOSDRECHT MCM (2001) Experience with guidelines for wastewater characterisation in The Netherlands. *Water Sci. Technol.* **45** (6) 77-87.
- SALEM S, BERENDS D, HEIJNEN JJ and VAN LOOSDRECHT MCM (2002) Model-based evaluation of a new upgrading concept for N-removal. *Water Sci. Technol.* **45** (6) 169-176.
- SIN G, INSEL G, LEE DS and VANROLLEGHEM PA (2004) Optimal but robust N and P removal in SBR's: A model-based systematic study of operation scenarios. *Water Sci. Technol.* **50** (10) 97-105.
- SIN G, VILLEZ K and VANROLLEGHEM PA (2006) Application of a model-based optimisation methodology for nutrient removing SBRs leads to falsification of the model. *Water Sci. Technol.* **53** (4-5) 95-103.
- STANDARD METHODS (1992) *Standard Methods for the Examination of Water and Wastewater* (18th edn.). American Public Health Association (APHA), Inc. New York.
- STRICKER A-E and RACAULT Y (2005) Application of Activated Sludge Model No. 1 to biological treatment of pure winery effluents: case studies. *Water Sci. Technol.* **51** (1) 121-127.
- THEIL H (1961) *Economic Forecasts and Policy* (2<sup>nd</sup> revised edn.) North Holland Publishing Co, Amsterdam.
- VANDEKERCKHOVE A, MOERMAN W and VAN HULLE SWH (2007) Full-scale modelling of a food industry wastewater treatment plant in view of process upgrade. *Chem. Eng. J.* **135** 185-194. Doi:10.1016/j.cej.2007.02.024.
- VANHOOREN H, MEIRLAEN J, AMERLINCK Y, CLAEYS F, VANGHELUWE H and VANROLLEGHEM PA (2003) WEST: Modelling biological wastewater treatment. *J. Hydroinf.* **5** 27-50.
- VAN HULLE SWH and VANROLLEGHEM PA (2004) Modelling and optimisation of a chemical industry WWTP subjected to varying production schedules. *J. Chem. Technol. Biotechnol.* **79** 1084-1091.
- VAN HULLE SWH, VERSTRAETE J, HOGIE J, DEJANS P and DUMOULIN A. (2006) Modelling and simulation of a nitrification biofilter for drinking water production. *Water SA* **32** 257-264.
- WENTZEL MC, EKAMA GA and MARAIS GvR (1992) Processes and modelling of nitrification denitrification biological excess phosphorus removal systems – A review. *Water Sci. Technol.* **25** (6) 59-82.
- WENTZEL MC, EKAMA GA and SÖTEMANN SW (2006) Mass balance-based plant-wide wastewater treatment plant models – Part 1: Biodegradability of wastewater organics under anaerobic conditions. *Water SA* **32** 269-275.
- ZHOU X (1993) A new method with high confidence for validation of computer simulation models for flight systems. *Chinese J. Syst. Eng. Electron.* **4** 43-52.