

# Rheo-processing of semi-solid metal alloys: a new technology for manufacturing automotive and aerospace components

L. Ivanchev<sup>\*†</sup>, D. Wilkins<sup>\*</sup>, G. Govender<sup>\*</sup>,  
W. Du Preez<sup>\*</sup> and R. Bean<sup>\*</sup>

The latest trend in the automotive industry to produce fuel-efficient vehicles has resulted in the increased use of aluminium and magnesium alloys. Liquid metal high pressure die-casting (HPDC) currently satisfies the bulk of the automotive industry's needs in this regard. Growing demands for improved quality and weight reduction, however, have been driving the development of new processing technologies. Problems inherently associated with liquid metal HPDC have resulted in enhanced interest in semi-solid metal (SSM) casting processes. The CSIR has developed and patented a novel SSM rheocasting process and equipment for semi-solid casting described here.

## Introduction

Some metal-forming processes—such as forging, rolling, extrusion, and drawing—are designed to be carried out when the metal is in the solid state, whereas casting is performed when the metal is a liquid. These two technologies have been known and used for thousands of years. In 1972, M.C. Flemings and his collaborators discovered that a casting process with the metal in a semi-solid/semi-liquid state was feasible and that there were many benefits relating to the properties of the finished product.<sup>1</sup> The process is called semi-solid metal (SSM) technology.

A semi-solid metal is in a thixotropic state, which is suitable for both casting and forging operations. Thixotropy is a special property of a gel that temporarily becomes liquid when sheared, and reverts to a gel when static. For a metal to become thixotropic, it must be heated to a temperature where it becomes semi-solid and has a globular microstructure [Fig. 1(b)] instead of a dendritic structure [Fig. 1(a)].

There are two versions of SSM technology which can produce metal slurries with resultant globular structures at an appropriate semi-solid casting temperature, namely, thixocasting and rheocasting. Thixocasting is a two-step process. In the first step, a continuous casting operation upgraded with a stirring device is used to

produce solidified metal with a non-dendritic structure. Rods with diameters from 75 mm to 150 mm are cast. During the second step, rods are cut from billets and then heated in an induction furnace to the desired semi-solid temperature. A big disadvantage of the thixocasting process is that the scrap and returns (unused material) cannot be recycled on site.

Rheocasting is a one-step process. The molten metal is treated by cooling or by cooling/stirring from liquid to a semi-solid temperature in order to produce a slurry with the globular shape of the solid phase followed by direct injection into a die. The big advantage of rheocasting compared with thixocasting is that the slurry can be made on demand and 'in house'. The chemical composition of the cast metal can also be modified and tailored to meet the quality and property specifications of the components. Scrap and other used metal can be directly re-melted in the rheocasting machine, which contributes to the lower produc-

tion costs of rheocastings and hence growing interest by research centres and industry.<sup>2-12</sup>

The main technological advantages of the SSM forming process are as follows: the production of parts with close to the desired final shape; excellent surface finishing; good mechanical properties; it allows for the casting of a wide range of metals including high-strength wrought alloys; the production of thin-walled components is facilitated; different heat treatments are possible; it is possible to weld parts by laser in an inert gas atmosphere; and the dies used to form the metal parts have a relatively long life. Table 1 lists typical automotive components, suitable for forming by SSM.

## SSM at the CSIR

A three-year R&D programme at the CSIR resulted in the patenting of a new rheocasting process and its associated equipment. A pilot slurry production unit was built for the creation of billets up to 4.5 kg in mass. The billets possessed very fine globular structure and the mechanical properties of cast products were fully comparable with international achievements. The production rate is about one casting per minute.

Two options were investigated with respect to the treatment process:

- Conversion of the liquid metal to a semi-solid state by stirring with an induced electromagnetic field, supplied by an a.c. induction coil, and simultaneous air cooling to the desired semi-solid temperature—an induction heating/stirring process.

Table 1. Automotive components suitable for SSM casting.

Car unit	Component
Brake systems	Brake callipers, master cylinder
Fuel supply systems	Fuel rails, petrol collectors, diesel engine pump
Engine and suspension	Engine block, suspension arms, engine mounts, belt cover, pulleys, pistons
Steering systems	Power-steering valve box, clutch cylinder, wheels

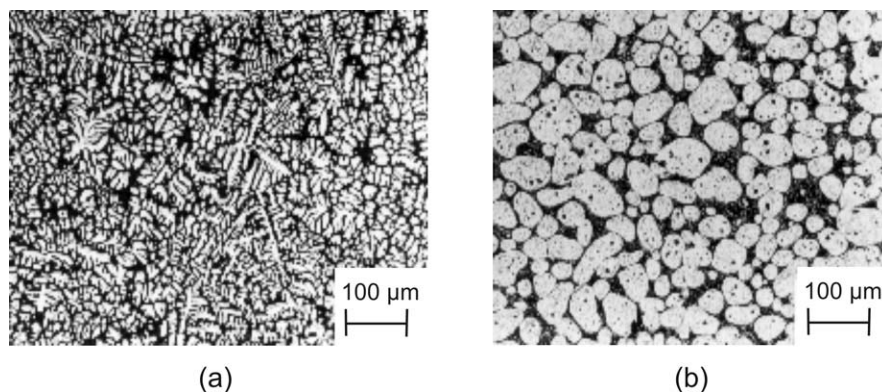

Fig. 1. (a) Dendritic microstructure typical of liquid castings, and (b) globular structure, which is typical of a semi-solid metal casting.

<sup>\*</sup>CSIR Materials Science and Manufacturing, P.O. Box 395, Pretoria 0001, South Africa.

<sup>†</sup>Author for correspondence. E-mail: livanch@csir.co.za

- Transformation of the liquid metal to a semi-solid state by air cooling and applying induction heating at the end of the process to release the billet from the cup (mould)—a controlled cooling treatment process.

Both processes were tested experimentally and we concluded that the induction heating/stirring process provides a better semi-solid metal structure than the controlled cooling treatment. This result can be explained by the stirring effect of the induced magnetic flux, which affects the crystallization of the metal in three main ways: (a) it disturbs the dendritic growth process by breaking up the small branches from the beginning of the crystallization process, decreasing their size and increasing the number of grains; (b) it rotates the crystal nuclei in the liquid metal and provides conditions for non-preferential directional growth on solidification that improves the grain shape, resulting in a smaller shape factor; (c) it mixes the volumes of metal at different temperatures in the cup, contributing to a more uniform temperature profile.

*Rheo-processing slurry maker.* Once the method of preparing the slurry was established, a prototype machine for producing SSM billets was designed and built. One of the core requirements for the equipment and process is that it be flexible so that it may be used with both horizontal and vertical injection HPDC equipment and be implemented in most existing HPDC foundries without significant capital investment. It also had to produce one billet per minute with the means to vary the cycle time as needed.

In the light of these requirements, the equipment for treatment of light metal alloys from a liquid state to a semi-solid slurry was developed (Fig. 2).<sup>13,14</sup> Cups with metal are moved in a vertical direction upwards and stepwise through three conditioning units, each of which consists of an induction coil and an air-cooling coil. The equipment can be operated as a single-coil or multi-coil unit, depending on production requirements and the material being processed.

*Evaluation of the equipment and process.* The equipment was evaluated using A356 aluminium casting alloy. An 8-kW electrical tilting furnace with a capacity of 18–20 kg aluminium was used for melting before casting. The melt at 630°C is poured into austenitic stainless steel cups, consisting of stainless tubes and assembled with a consumable washer, made of the same or similar cast alloy. The washer becomes part of the biscuit after casting.<sup>15</sup>

The cup charged with the liquid metal

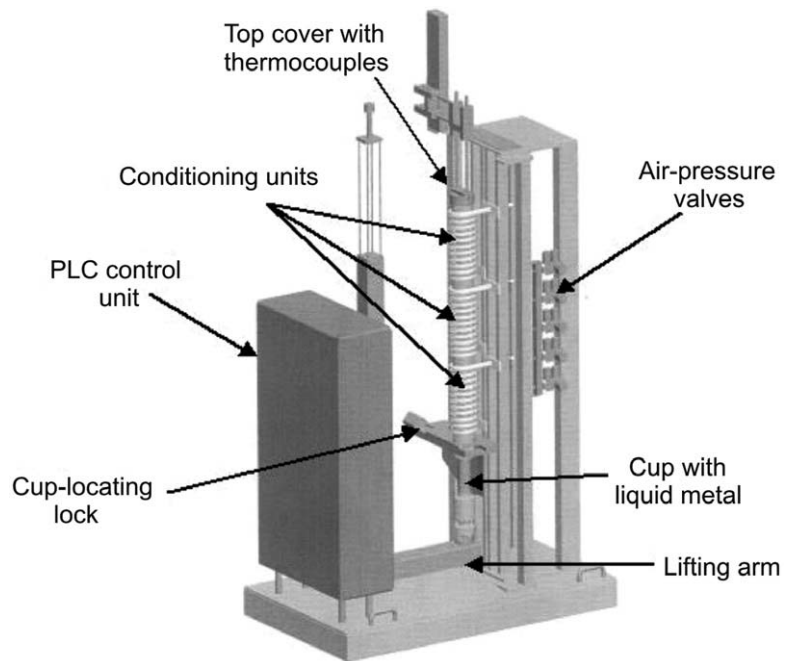

Fig. 2. The CSIR's rheo-processing slurry maker for continuous delivery of semi-solid billets.

is transferred to the slurry-making apparatus and processed using a three-minute induction heating/stirring and cooling cycle. The process is optimized to produce semi-solid slurries with a temperature range of 580–585°C. The power and cooling profiles used for processing of the metal are dependent on the cup size/metal volume and alloy composition.

After completion of the slurry-making process, the cup is transferred to the HPDC machine and placed in a special clamping mechanism of the shot sleeve (Fig. 3).<sup>15</sup> The cup is clamped, becoming a part of the shot sleeve and the slurry metal is injected into the die. The washer becomes part of the biscuit. On completion of the casting, the cup is ejected and

reconditioned for the next casting. A 50-ton Edgewick HPDC machine was used during these trials.

## Results and discussion

*Microstructures.* The microstructure analysis revealed a globular non-dendritic structure (Fig. 4). The average grain size,  $D_a$ , was determined to be 68–85  $\mu\text{m}$ , and shape factor,  $F_a$  (the ratio between the biggest and smallest grain dimensions), varied from 1.43–1.52. The structural homogeneity of 60-mm-diameter by 180-mm-long billets was evaluated in six critical positions of the volume: top cross section (edge and centre), middle cross section (edge and centre), and bottom cross section (edge and centre). Standard

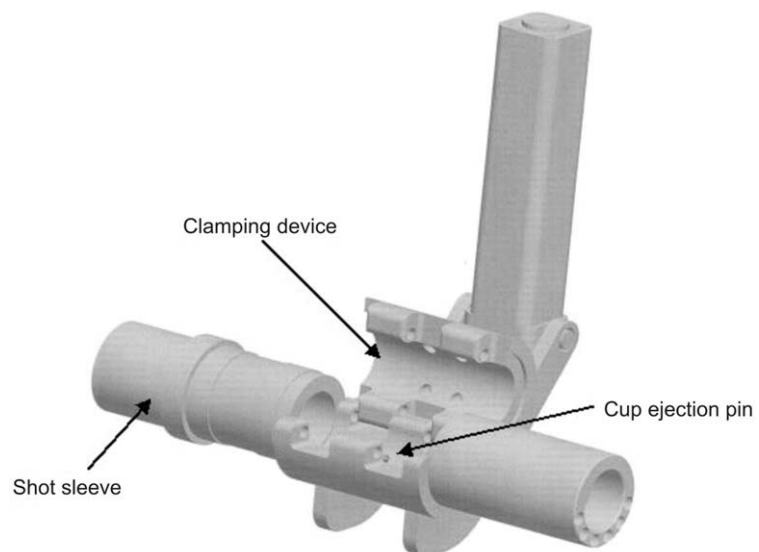

Fig. 3. An HPDC machine shot sleeve with cup-clamping device.

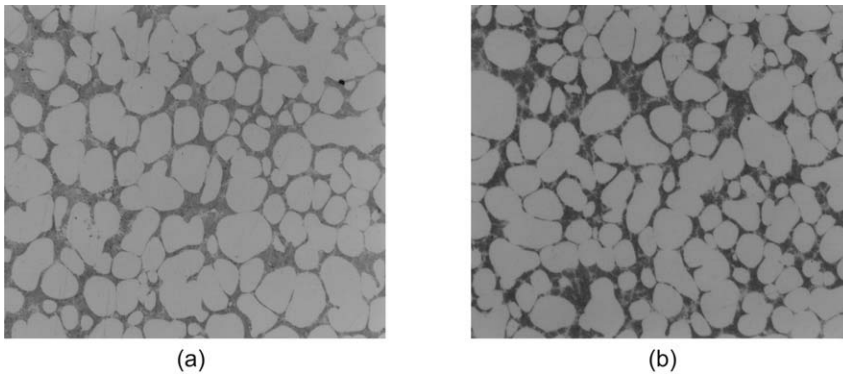

Fig. 4. (a) Microstructure of a 60-mm-diameter billet of A356 aluminium casting alloy (average grain size 68  $\mu\text{m}$  and shape factor 1.43); (b) 90-mm-diameter billet (average grain size 85  $\mu\text{m}$  and shape factor 1.52).

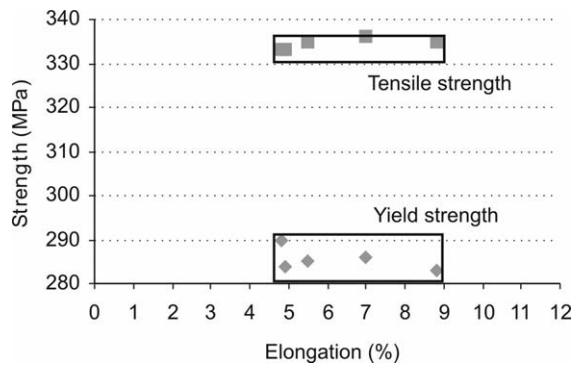

Fig. 5. The highly consistent mechanical properties of A356 aluminium casting alloy after HPDC and T6 heat treatment.

deviations of the grain size and the shape factor in the whole volume of a billet were 8.8% for  $D_a$  and 3.9% for  $F_a$ . The microstructure was uniform throughout the billet, with no evidence of eutectic segregation.

Chemical analysis after casting showed that the metal composition was within the alloy specification (in weight %: Si, 6.62; Fe, 0.13; Mn, 0.01; Mg, 0.43; Ti, 0.02; Cu, 0.02; Sr, 0.028; Zn, 0.05; Al, balance).

**Mechanical properties** Cylindrical bars were cast and heat treated according to a T6 condition (heating at 540°C for 6 h, followed by 170°C at 6 h). Round tensile specimens, with a diameter of 7.5 mm and gauge length of 50 mm, were machined and tested using a 25-kN Instron tensile testing machine. The tensile and yield strengths were found to be highly consistent, while the ductility varied between 4.8% and 8.8% (Fig. 5).

## Conclusions

We have therefore established a reliable and stable process and associated equipment for the treatment of aluminium alloys from a liquid to a semi-solid state. The method has subsequently been applied successfully for rheocasting of magnesium alloy AZ91D<sup>16</sup> and the metal

matrix composite alloy F3S.20S.<sup>17</sup> Slurry billets with diameters of 50 mm, 60 mm and 90 mm and lengths of up to 200 mm have been cast. These dimensions are not the limits of the process, and billets with larger diameters and lengths can be produced. A 15.5-kg billet has recently been cast.

The characteristics of the cast A356 alloy achieved with this technology were:

- Maximum temperature variation in a single billet: 4°C
- Grain size: less than 85  $\mu\text{m}$
- Shape factor: less than 1.52
- Mechanical properties in the T6 condition: yield stress: 262–290 MPa; ultimate tensile strength: 322–336 MPa; elongation 6–14%
- Production rate: one billet per minute.

These achievements are significant for the fabrication and the mechanical properties of a cast component. Both grain size and shape factor determined the viscosity of the semi-solid slurry—smaller values lead to better castability. The grain size of the primary crystals has to be below 100  $\mu\text{m}$  and the shape factor no greater than 2 for a component with a complicated shape to be cast.

A small temperature gradient in a single metal billet contributes to the uniform

mechanical properties in a casting. The mechanical properties of the semi-solid casting are influenced in the same way—a finer microstructure determines higher yield and ultimate tensile strength, and improved plasticity. The mechanical properties of this alloy, A356, after conventional liquid chill mould casting and the same T6 heat treatment, are: 186 MPa yield strength, 262 MPa ultimate tensile strength and 5% elongation. A production rate of one unit per minute is quite sufficient for operation in realistic production environments.

1. Spencer D.B., Mehrabian R. and Flemings M.C. (1972). Rheological behaviour of Sn-15% Pb in the crystallisation range. *Met. Trans.* 3, 1925–1932.
2. Richard K.L., Neil Jr, R.I., Rice C.S., Myojin S., Mendez P.F., Gage T.B., O'Daniels J.F. and Barton C.E. (2003). Semi-solid casting apparatus and method. US Patent 6,640,879 B2, Nov. 4, 2003.
3. Orii S. (2003). Method for manufacturing of metallic slurry for casting. US Patent 6,595,266 B2, Jul. 22, 2003.
4. Norville S.M.D., Wang S. and Lombard P. (2002). Method and apparatus for making a thixotropic slurry. US Patent 6,432,160 B1, Aug. 13, 2002.
5. Lombard P.J., Wang S., Winterbottom W.L. and Spiller G. (2003). Apparatus for producing a metallic slurry material for use in semi-solid forming of shaped parts. US Patent 2003/0102103 A1; Jun. 5, 2003.
6. Flemings M.C., Martinez-Ayers R.A., de Figueiredo A.M. and Yurko J.A. (2003). Metal alloy composition and process. US Patent 2003/0079854, A1, May 1, 2003.
7. Aoyama S., Liu C., Sakazawa T. and Pan Y. (2003). Method of producing semi-solid metal slurry. US Patent 2003/0062144, A1, Apr. 3, 2003.
8. Winterbottom W.L., Chiriac D.V., Unruh J.M. and Lu J. (2003). Apparatus for and method of producing slurry material without stirring for application in semi-solid forming, US Patent 2003/0037900, A1, Feb. 27, 2003.
9. Flemings M.C., Martinez-Ayers R.A., de Figueiredo A.M. and Yurko J.A. (2002). Metal alloy composition and process. US Patent 2002/0096231, A1, Jul. 25, 2002.
10. Adachi M., Sasaki H., Sato S. and Atsushi Y. (1994). Method for shaping of semisolid metals EP 0 745 694 A1, 1994. US Patent 6,769,473 B1, Aug. 2004.
11. Adachi M., Sato S., Harada Y. and Kawasaki T. (2000). Apparatus for producing metal to be semimolten-molded. US Patent 6,165,411, Dec. 2000.
12. Yurko J.A., Martinez R.A. and Flemings M.C. (2003). Commercial development of the semi-solid rheocasting (SSR tm) process. *Metall. Sci. Technol.* 21(1), 10–15.
13. Bruwer R., Wilkins J.D., Ivanchev L.H., Rossouw P. and Damm O.R.F. (2004). Method and apparatus for rheo-processing of semi-solid metal alloys. US Patent 7,225,858 B2/Jun. 5, 2007.
14. Ivanchev L., Wilkins D. and Govender G. (2004). Method and apparatus for rheo-processing of semi-solid metal alloys. In *Proc. 8th S2P Conference*, Sept. 21–23, Cyprus.
15. Ivanchev L. and Wilkins D. (2003). Processing of a molten alloy. US Patent 2007/0079949 A1/Apr. 12, 2007.
16. Govender G. and Ivanchev L. (2004). SSM HPDC of magnesium alloys AZ91D and AM60B. In *Proc. 8th S2P Conference*, Sept. 21–23, Cyprus.
17. Ivanchev L. and Govender G. (2004). Rheo casting of Duralcan composite F3S.20. In *Proc. 8th S2P Conference*, Sept. 21–23, Cyprus.