

Are solar tracking technologies feasible for domestic applications in rural tropical Africa?

Kant E Kanyarusoke^a

Jasson Gryzagoridis^b

Graeme Oliver^a

a. Department of Mechanical Engineering, Cape Peninsula University of Technology, Cape Town, South Africa

b. Department of Mechanical Engineering, University of Cape Town, South Africa

Abstract

That solar tracking improves energy yields from solar harvest systems is not debatable. Nor is the under powering of tropical Africa amidst plenty of energy resources – including solar. This paper presents a review of recent literature on tracking as applied to domestic solar harnessing devices. The purpose is to find basic requirements in design of a suitable solar tracker for the region's rural homes. It is concluded that Single axis passive trackers possibly will stand better chances of acceptability in the region.

Keywords: tropical Africa, solar tracking, solar energy, domestic application

1. Introduction

It is an established fact that tracking improves energy yields from solar harvest devices. But there are doubts about the efficacy of this improvement for small systems and in high diffuse radiation areas. Mousazadeh *et al.* (2009), for example, advise against use of tracking for small systems because of disproportionate energy consumption by the tracking mechanisms. Elmer (2006) reported a lack of significant total energy gain from solar tracking in Great Britain because of excessive diffuse radiation. In Hanover, Germany, Beringer *et al.* (2011) reported that the tilt angle of fixed panels was nearly irrelevant as far as total annual yields were concerned. Does this mean tracking does not yield more energy? – Not necessarily. Kanyarusoke *et al.* (2012a) showed that at latitude (L), a fixed slope (β) surface

receives radiation at a best angle on the day when the sun declination (δ) satisfies the condition in equation (1). Hence all fixed surfaces do so at their appropriate times. Whether the total annual yield for one inclination is higher than that at another depends on additional factors like climatic conditions.

$$\beta - |L - \delta| = \text{Minimum} \quad (1)$$

Tracking enables multiple repetition of this condition – and hence can in general be expected to increase yield as reported by many researchers and inventors in different circumstances. Theoretical analysis on photovoltaic yields from a 180 Watt peak panel at 80 African weather stations (Kanyarusoke *et al.*, 2012b) seemed to suggest there can be substantial gains using various modes of tracking except in rainy equatorial and sandy, windy Sahel regions. There, effects of diffuse radiation were as important as in Elmer's case above. Focusing on systems for home use, this paper reviews available literature on tracking devices.

The paper is organized as follows: Section 2 gives a short brief about tropical Africa. Focus is on energy and technical issues affecting tracker marketing. Section 3 reviews the trackers. Section 4 summarises issues about the technologies in the target market segment.

2. Tropical Africa: Energy issues and solar tracking needs

Tropical Africa is that part of the continent lying between latitudes $\pm 23.5^\circ$. This means the sun is directly overhead twice annually. It also means the

sun's rays do come from the northern and southern directions at different times of the year. Hence, the use of fixed slope panels facing either direction poses problems of missing beam radiation at certain times of the year.

This region is described by the International Energy Agency (IEA) as underpowered because of inadequate grid power supply (IEA 2011). Hence, self-generation is a necessity in many situations. At village level, the easiest, safest and most convenient form of self-electric generation is to use photovoltaic (PV) systems. But PV systems' thermodynamic efficiencies are in the 10 to 16% range. Ideally therefore, they should be installed to track the sun so as to maximise incident energy if costs of doing so are justified by additional yield.

The only area where tracking is being used out of necessity is in concentrated solar power (CSP) systems. Nigeria has many documented research outputs on this. Between Oyetunji's (1989) work on composite conical concentrators, Oyetunji *et al.* (1989) and Abdulrahim's (2008) PhD work on bifocal solar tracking and (Abdulrahim *et al.*, 2010), there were not less than seven significant contributions at honours and M Sc degree research levels in the area.

The extensive energy poverty in tropical Africa amidst an abundant solar resource supply and a growing middle class means that a large potential for innovative solar energy harvesting devices exists. The progressive efforts by African governments to increase the solar resource component in their energy mixes (Karekezi, 2002; Bugaje, 2006; UN, 2007; Brew-Hammond and Kemausuor, 2009) and to rural-electrify (UNEC, 2006; Fluri, 2009; Brent and Rogers, 2010; Pegels, 2010; UN, 2014) create opportunities for a mass market of suitably designed solar tracking devices not just to cater for

PV and CSP but also for Solar Thermal (ST) applications.

In summary therefore: first, there is a big potential for solar engineering development for tropical African homes. Secondly, some of these applications need to track the sun. But even where systems are being developed, tracking is limited only to where it is absolutely essential.

3. Solar tracking technologies

Solar tracking is the act of making a solar collection surface change its orientation with the movement of the sun in the sky. There are two significant relative motions in the earth-sun system. The first is the diurnal movement due to the earth's rotation about its axis, causing day and night. This is responsible for the hourly variation of incident solar radiation on a surface. The second is the much slower movement due to the earth's elliptical voyage round the sun. Two factors in this motion combine to affect incident radiation. First, the actual sun-earth distance affects the extra-terrestrial radiation in accordance with an inverse square law. Secondly, the angle between the earth's equatorial plane and its orbit causes an apparent seasonal north-south range of travel of the sun in the upper celestial hemisphere. Figure 1 shows the relative motions.

Full control of solar harvest surface orientation is therefore a 2-degree of freedom problem. In practice, control is achieved by manipulating rotations about 2 of any 3 orthogonal axes. Commonly used axes are: West-East; North-South in the horizontal plane and the vertical Nadir-Zenith. Mousazadeh *et al.* (2009), Kelly and Gibson (2010), Barsoum and Vasant (2010), Seme *et al.* (2011), Tina and Gagliano, (2011) – among others – report the following pairs to constrain the rotation as to keep the surface facing the sun all day long.

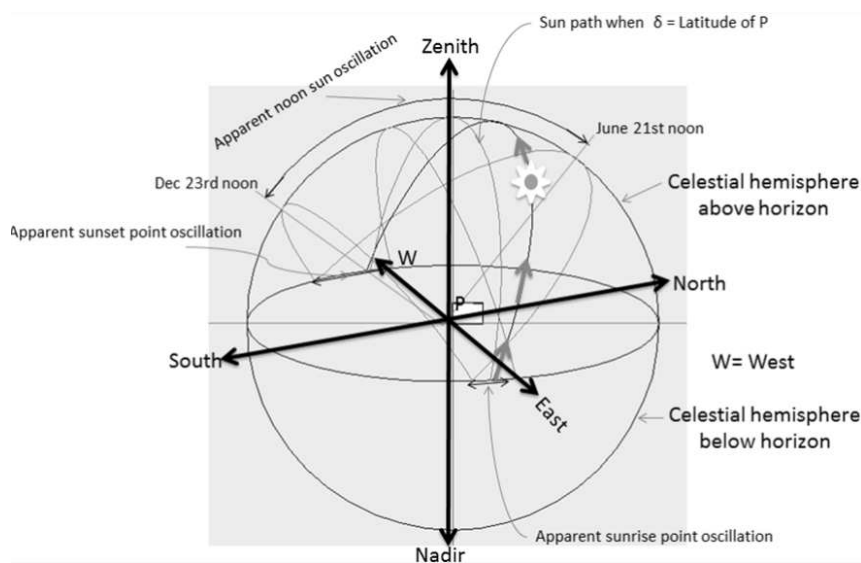

Figure 1: Apparent sun motion on the 'inside' surface of an inverted celestial hemisphere for a place 'P' within the tropics

- W-E and S-N
- S-N and Nadir – Zenith
- Nadir – Zenith and W-E

Rotation about these axes affects the surface slope β and its azimuth ψ . Tracking manipulates these angles to vary with the sun angles: the elevation α and the solar azimuth ψ_{ss} . These are dependent on the time and day of year. Hence, from a tracking point of view, they are independent variables. Figure 2 shows the four angles.

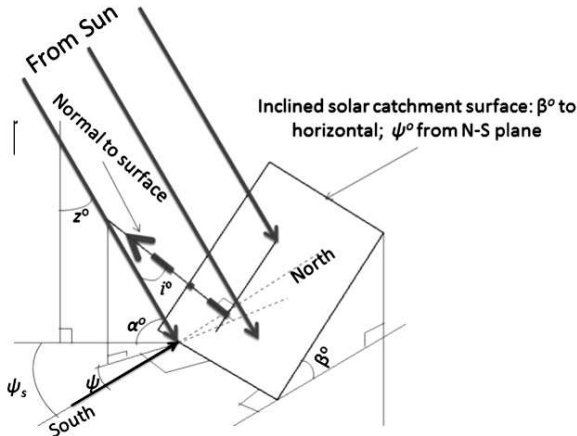

Figure 2: Important angles for a solar tracking surface: 'i' is the incidence angle to be minimised

Broadly, the angles β and ψ track α and ψ_s using mechanisms classified according to two criteria (Helwa, *et al.*, 2000; Markvart, 2000; Chong and Wong, 2009):

- Passive or Active tracking
- One axis or Two axes tracking

3.1 Passive tracking

When the radiation catchment plane or aperture is adjusted without use of electrical power, the tracking is said to be passive.

Passive single axis trackers

Passive tracking on one axis is commonest in solar thermal systems employing tubular absorbers. These include (Winston, 2001; Kalogirou, 2007): compound parabolic collectors (CPCs), linear Fresnel reflectors (LFRs), parabolic trough collectors (PTCs) and cylindrical trough collectors (CTCs). The radiation catchment plane is directed to the sun usually in incremental steps about either a horizontal S-N or one parallel to the earth's rotational axis.

One example of a passive tracker is that by Zomeworks. It uses a refrigerant under suitable pressure in two cylinders running along the edges of the radiation catchment surface as shown in Figure 3. The cylinders are shaded and connected by a pipe/tube. When the incident radiation is not normal to the catchment plane, one of the cylinders is heated more than the other. Some of the refrigerant in the affected cylinder evaporates to create a new saturation pressure. The pressure rise forces some liquid into the cooler shaded cylinder, causing an extra torque to act on the structure's rotational axis. The shading is designed such that this torque turns the un-shaded cylinder towards shade. Damping helps stabilise the system quickly.

The main problems with the Zomeworks tracker are: lack of an evening/night return mechanism; slow wakeup response in the mornings due to limitation on the surface inclination angle β . Poulek (1994) and Full (2010) have faulted the use of refrigerants on account of environmental and safety concerns. Use of safer refrigerants like R134a can help address this issue.

Poulek developed a tracker using a shape memory alloy (SMA) to actuate the rotation. Two identical cylindrical actuators were symmetrically encased in a rotating cylinder with a lens at its opening as shown in Figure 4. Each actuator's one end joined a plane mirror attached to the rotating case while the other end was fixed to the frame (stator) sup-

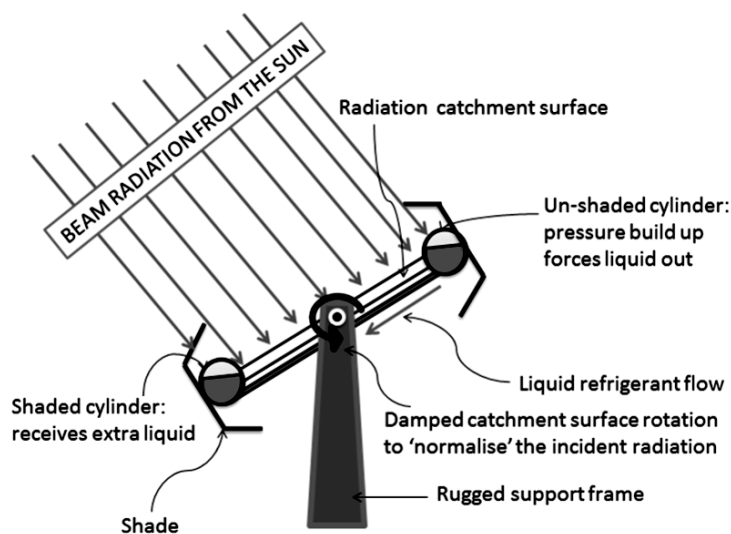

Figure 3: Zomeworks solar tracker – principle of operation

porting the radiation catchment plane. When the plane is properly oriented to the sun, the lens focuses the radiation onto the mirror which reflects it back preventing the SMAs from receiving it. On misalignment however, one of the SMAs receives the radiation, gets heated above its transformation temperature and then changes shape, rotating the mirror – and hence the plane – until radiation is again incident on the mirror.

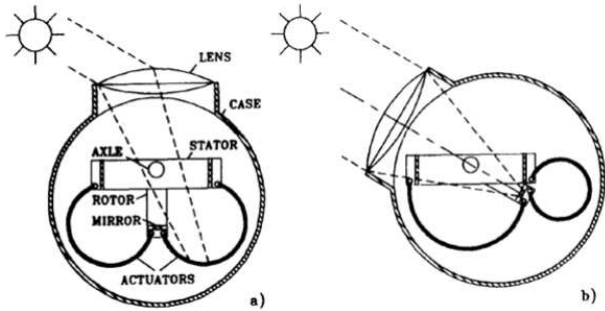

Figure 4: Poulek's single axis passive solar tracker
 With permission from Elsevier: *Solar Energy Materials and Solar cells*: 33 (1994): 288 & 289

The tracker uses Cu-Zn-Al alloy. Because of the material's high damping characteristics, oscillations do not arise. It returns itself to morning conditions at night. Its downside is the 140° swing limit – meaning some energy harvest in the mornings and evenings is lost.

Clifford and Eastwood (2004) designed a tracker using the more common and robust aluminium/steel bimetallic strips. The strips are shaded and attached to the edges of the radiation catchment plane like the cylinders in the Zomeworks tracker. The more expansive aluminium is on the outside. Connected to the strips midpoints are masses which help amplify moments caused by the differential expansion on heating. The resulting net moment turns the radiation catchment plane to shade the hot strip. A mass-damper-thermally induced spring

system was able to achieve a tracking range of 120° under lab conditions in the UK.

Although the design had equatorial regions in mind, it wasn't field tested in the target area. Full (2011) made a similar design in Kenya, using the strips and turning on a shaft from locally available bamboo plants. The tracker was reported to help increase photo-electricity generation by 38%. Still in rural Kenya, Mwithiga and Kigo (2006) developed a manually operated coffee beans dryer (see Figure 5). But the tracking labour cost could not be justified for a low value crop like coffee.

In his PhD thesis, Abdulrahim (2010) reviewed work that had been done in Nigeria especially on solar concentrators. Works by Oyetunji, et al. (1989) and by Suleiman, et al. (1989) at Ahmed Belo University (ABU) were cited. Oyetunji's group was reported to have worked on conical concentrators while the latter group worked on cylindrical collectors. All tracking was manual. In the 1990s, works by Musa, et al. (1992), Ajiya (1995), and Mshelbwala (1996) were reported. Musa's work group designed, constructed and tested a Fresnel concentrator which they manually tracked every 20 minutes. In spite of the improved performance, the labour requirement was too much to let the project proceed. Ajiya designed and tested a manually steerable parabolic cooker. It performed satisfactorily – achieving 30% energy efficiency. Mshelbwala modified the cooker by supporting the cooking pot to directly receive the reflected radiation. He reports to have raised the efficiency to 46.6%.

This century has seen improvements on earlier designs and further developments at many research centres across Nigeria – eventually culminating in the mechanically tracked bifocal collector of Abdulrahim's doctoral thesis in 2008. Ahmed (2001) improved parabolic trough collection at ABU. Pelemo, et al. (2002a, b, 2003) worked on circular parabolic concentrators – improving concentrating ability, and demonstrating applications in water distillation. Abdulrahim's mechanical tracker – the first recorded mechanical tracker in Nigeria –

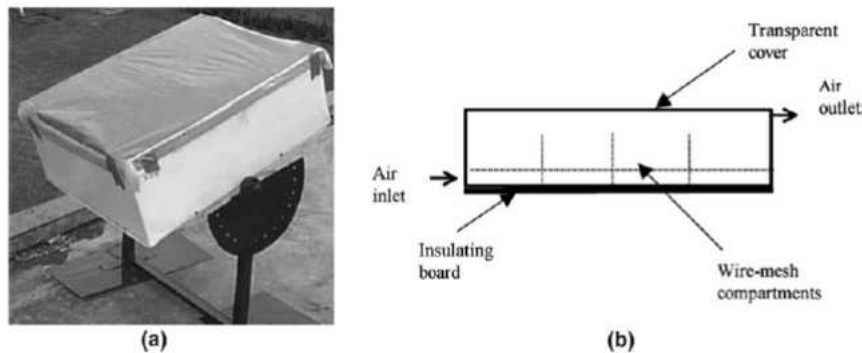

Figure 5: Mwithiga and Kigo's coffee bean manual sun tracking dryer
 With permission from Elsevier: *Journal of Food Engineering* 74 (2006):248

was powered by a dropping weight that operates a clock mechanism driving the collector through a chain drive.

Outside Africa, only a few additional passive devices have been developed because focus has been on active systems. Hitchcock (1976) patented a buoyancy powered unit for the US navy. An array of Fresnel reflectors was kept pointed to the sun using water. Buoyancy produced movement whenever individual reflector elements were out of alignment. The issues with this tracker are that in morning hours, it takes about one hour to 'wake' up; it needs very precise manufacturing and assembly and uses a lot of water. It is big and not suitable for domestic applications.

Yi and Hwang (2009) patented a water driven tracker for Kun Shun University, China. A frame carries a pivoted radiation catchment surface. On either side of the pivot are spring supported water tanks with inlet and outlet valves. With the frame oriented in a W-E direction, one tank is filled with water at night while the other is emptied. This makes the surface face eastward. In the morning, the full tank is emptied in predetermined steps such that the frame incrementally tilts westward at an approximate uniform rate of 15° per hour. By solar noon, the tank is empty – and the frame takes on a horizontal position. When this happens, incremental filling of the western tank begins. Consequently, the catchment surface continues its westward rotation tracking the sun in the afternoon. The night operation of emptying the western tank and filling the other completes the cycle for the day.

The invention's merit is in its relative simplicity and automated filling and refilling of tanks as driven by a pre-programmed clock mechanism. It apparently has no 'wake up' issues. It is not clear if the water from one tank is preserved for use in the other and what mechanism is used to transfer the water in a night operation.

Passive two axes trackers

Many single axis trackers can be turned into full tracking types by providing independent means to turn about a second axis perpendicular to the first one. In fact, manual mobile types use this approach to orient the panel. The second axis for these cases is almost always vertical. An obvious problem is the additional cost and complexity for the expected energy gains. The single axis W-E tracking will have improved yields by 20 – 30% (Bekker, 2007; Rabinowitz, 2011; Kanyarusoke et al. 2012a, b; Sobamowo et al., 2012). The additional 5 to 10 percentage points may not easily be justified. This is particularly true in the tropics where the sun's noon zenith angle cannot exceed 47° and therefore the additional gain is at the lower end. The closer to the equator, the smaller will be the necessity to double track.

However, three recent patents have surfaced. Of these, only one is suitable for smaller domestic systems. It is similar to an 'improved' Zomeworks'. Djeu (2004) patented a passive full tracker for a solar concentrator that could be visualised as shown in Figure 6. A reflecting/refracting system focuses radiation onto a fixed collector. The energy receiving sub system is mirrored about a central plane for balancing purposes. One Gimbal rotates about an N-S axis and carries the optical system – with its balancing subsystem. The other rotates about an E-W axis. The fixed energy collection surface contains the point of intersection of the two axes. Refrigerant is held in shaded canisters at either end of the axes. The canisters for each axis are connected by piping as in the Zomeworks system.

The technical issues with this system are mainly to ensure proper balance of the gimbal and the usual 'wake up' and maximum inclination angle problems.

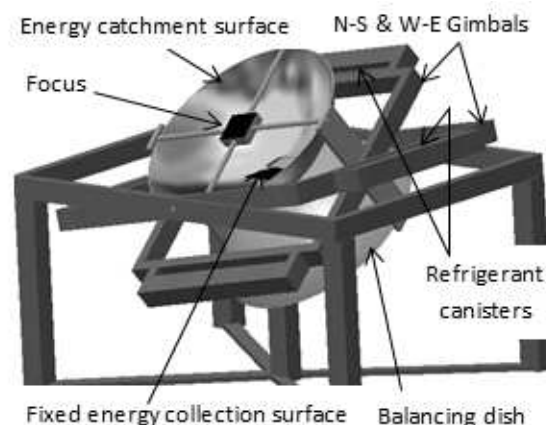

Figure 6: A 3-D visualisation of a typical Djeu's 2004 passive full tracker

3.2 Active tracking

Active trackers use electricity to drive the mechanism. They use any of 3 methods to sense the sun relative position: Light dependent resistors (LDRs), Photo transistors and Photocells. The devices are arranged in pairs to detect differential illumination which is transduced to an amplifiable voltage. The amplified signal is then used in a control circuit to drive a motor rotating the mechanism about an axis of interest. In general, each control axis will have its own sensing-control-motor-drive set up. Thus, single axis tracking has one set while two axes trackers have two sets.

Active single axis trackers

There are few active single axis trackers. Zerlaut and Heiskell (1977) patented a tracker with a clock override for Desert Sunshine Exposure Tests Inc. The override prevents fooling of the tracker by bright objects in the sky when the sun is occluded. Rizk and Chaiko (2008) designed a unit capable of

supporting an 8 kg 75 W panel using simple scrap parts. On a 9 Wp rated panel, they generated 6.3 W against 3.51 W when the panel was horizontal. While this is a substantial gain, it would have been more appropriate to compare yields with those from an inclined panel – since Australia is situated well south of the equator – and the optimal fixed slope panel is not expected to be zero. The tracker consumed 48 mW under no load conditions – or less than 1% of total power generated.

Active two axes trackers

Most amply reported active trackers are of the two axes type. Bakos (2006) reports use of 2 sets of LDRs as sensors to drive a 1370 rpm, 0.37 kW motor on the W-E axis and a 930 rpm, 0.75 kW one on the vertical. It is an electromechanical drive employing 4 relays and 2 electronic circuits connected to a computer with suitable software. A 46.46% energy gain when compared to a fixed 40° slope panel is reported. Louchene et al. (2007) report the use of fuzzy logic in generation of command signals to the drive motors.

Barsoum and Vasant (2010) report the design of a simplified full axes tracking system shown in Figure 7. It uses LDRs and varies the panel's azimuth and slope.

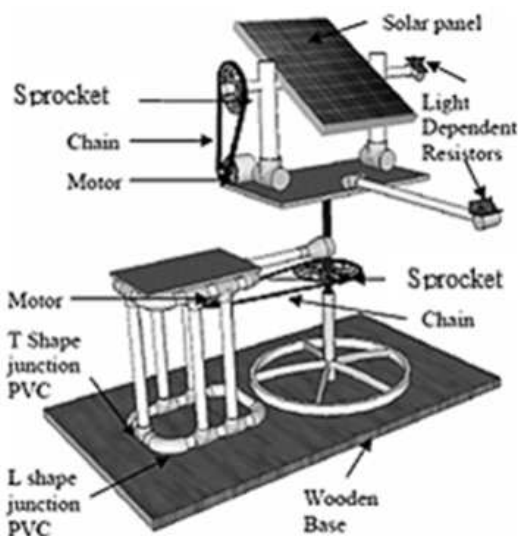

Figure 7: Barsoum and Vasant's solar tracking prototype

(With permission from: Global Journal on Technology and Optimisation Vol. 1, 2010 pp38-45)

Meyer (2010) patented a unit using lead screws driven by stepper motors to adjust the collection surface at two places. The surface was supported on spherical bearings at a third point. Martinez (2010) reports a bigger variant of linear positioning control. Hydraulic actuators in two orthogonal directions do the positioning. It is not suitable for rural African homes. Sobolewski et al. (2011) patented a roof mounted PV tracker at Rutgers, The

State University of New Jersey, US. The tracker is mounted at the apex of an East-West roof to maximise tracking angles in these directions. Figure 8 gives the arrangement and the reported limit angles.

While this is an improvement on other roof mounted systems, it still leaves a big fraction of hours under non optimal tracking conditions.

4. The technologies and relevance in Tropical Africa's context

Research on tracking technology developments in tropical Africa is rather scarce. It is mainly Nigeria and Kenya showing some limited activity on the international scene. Fairly recent work in other developing countries has been reported, particularly in China, work by Wu Chun –Sheng et al. (2008) on automatic sun tracking and that by Chia-Yen Lee et al. (2009) on general tracking mechanisms. In the Middle East, Arafat et al. (2010) work was looked at. Quite earlier in the history of solar thermal electricity technology, Mill's global review is of interest. (Mill, 2004). So is Tomson's simplified two position tracker (Tomson, 2007). Recent work by Slama and Combarous (2011) on orange peels drying in Tunisia can help improve performance of crop dryers using solar thermal systems.

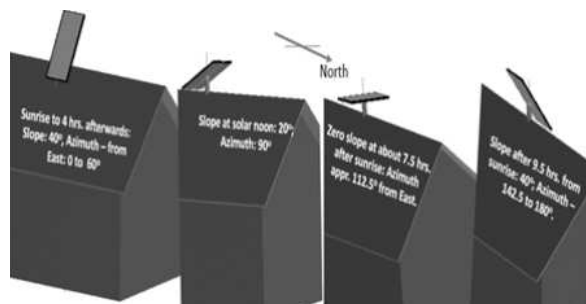

Figure 8: Sobolewski et al.'s roof apex mounted full tracker and the tracking angles progression across the day

The following works between 2012 and early 2013 are also noteworthy: Kelly and Gibson (2012) patented a cloudy-conditions tracker for General Motors Global Technology Operations. It automatically changes to a horizontal slope when the sun is occluded. This maximises diffuse radiation capture. In China, He et al. (2012) used a parallel links mechanism to track on two axes. They report motor power consumption reduction of up to 70%. Ghazali and Rahman (2012) investigated performance of amorphous, poly and mono crystalline solar panels under tracking conditions in Malaysia. They found that polycrystalline panels did best. In Bangladesh, Rahman et al. (2013) used LDRs and two amplifiers to demonstrate a gain of 52.78% energy yield between fixed slope and two axes tracking.

These technologies are yet to be fully adopted in Tropical Africa's homes. Apart from the fact that domestic solar energy systems are still few, there are issues with the technologies that may need to be addressed before widespread adoption.

4.1 Problems with the technologies

From tropical Africa's perspective, Table 1 summarises possible pertinent technology issues under the headings of energy sourcing; sensing and actuation.

5. Conclusion

In this paper, the more recent tracking technologies were reviewed. It was found that current technologies have many issues to resolve before adoption at a domestic level in rural Africa. Functionality, legality, security, operability and maintainability were some of the issues encountered.

In absence of empirical long term tracker performance data in the region, it is difficult to give definitive recommendations on type(s) of trackers which will be most successful. A particular tracker's acceptance elsewhere is not a guarantor of its success in the region. This is because the art of tracking can theoretically be implemented by many competing low level technologies as described in parts of the survey above. Never the less, single axis trackers showed that clock controlled passive track-

ers with weights of either solids or non-polluting liquids could possibly stand better chances of acceptability in the region.

Acknowledgement

This research is being funded by the Cape Peninsula University of Technology – to whom we are grateful.

References

- Abdulrahim A.T., Diso I.S. and El-Jumma A.M. (2010). Solar concentrators' developments in Nigeria: a review, *Cont. J. Eng. Sci.* 5 (2010) 38-45.
- ADB see Africa Development Bank.
- Africa Development Bank, The Middle of the Pyramid: Dynamics of the Middle Class in Africa. http://www.afdb.org/fileadmin/uploads/afdb/Documents/Publications/The%20Middle%20of%20the%20Pyramid_The%20Middle%20of%20the%20Pyramid.pdf [14th July 2011].
- Ahmed M.B. (2001). Design, Fabrication and Performance evaluation of an improved solar concentrating collector using slat-mirrors, Unpublished MSc. Eng. Thesis, Mech. Eng. Dept. Ahmed Bello University, Zaria Nigeria, 2001.
- Ajiya M. (1995). Design and Construction of a parabolic solar cooker, Unpublished B Eng project. Mech. Eng. Dept. University of Maiduguri, Nigeria, 1995.
- Anonymous. (2011). Canadian Teen Makes Cheaper,

Table 1: Summary of key issues in surveyed solar tracking mechanisms

Area	Alternatives	Issues
Energy source	Manual	Not viable because it is labour intensive
	Weights	Counter weights for balancing and control Frequent reloading
	Solar thermal	Speed of response Availability in case of cloud cover Evening and morning collection effectiveness
	Hydraulic	Pressure head source Needs reliable working fluid supply
	Springs Electricity	Frequent re energising Needs electric source Complex control system
Sensory system	Clock	Insensitive to diffuse radiation effects
	Shading	Affected by sky objects and delayed action
	Photo sensor	Needs electronic circuitry and unequal ageing of sensors
System Actuation	Manual	Tedious because it is labour intensive
	Clock	Separate programming
	Bimetallic strips	Low thermal efficiency Low tracking angle range 'Wake up' and evening return problems
	Shape memory alloys	Low tracking angle
	Vapour pressure	Use of refrigerants which must be eco-friendly 'Wake up' and evening return problems
	Electric motors	Possibly too costly – require sub system Maintenance of attendant control & drive elements
	Linkages	Power losses – require sub system Bulk and maintenance issues
	Hydraulic	Pressurised liquid reservoir Size and maintenance issues

- More Efficient Solar Tech., *Altern. Energy Afr.* 6th June 2011.
- Arifat K.Md.T. Shahrear T.S.M., Rifat R., and Shafiul A.S.M. (2010). Design and Construction of an Automatic Solar Tracking System. *ICECE*, 2010. 326 – 329. eeexplore.org/stamp/Stamp.jsp?tp=&arnumber=5700694 [23 Feb 2013].
- Bakos C.G. (2006). Design and Construction of a two – axis sun tracking system for parabolic trough collector (PTC) efficiency improvement, *Renew. Energy*. 31 (2006) 2411-2421.
- Barsoum N., and Vasant P. (2010). Simplified solar tracking prototype, *Glob. J. on Technol. & Optim.* 1 (2010) 38-45.
- Bekker B. (2007). Irradiation and PV array energy output, cost, and optimal positioning estimation for South Africa, *J. Energy in S. Afr.* 18 (2) (2007) 16-25.
- Bennett, L. (2008). Assets under Attack: Metal Theft, the Built Environment and the Dark Side of the Global Recycling Market. *Environmental law and Management*. 20(2008) 176-183.
- Beringer S., Schilke H., Lohse I., and Seckmeyer G. (2011). Case study showing the tilt angle of PV plants is nearly irrelevant. *Sol. Energy*. 85 (2011) 470-476.
- Brent, A. C. and Rogers, D. E. (2010). Renewable Rural Electrification: Sustainability Assessment of Mini-Hybrid off-grid Technological Systems in the African context. *Renewable Energy*. 35(2010) 257-265
- Brew-Hammond, A & Kemausuor, F. (2009). Energy for all in Africa—to be or not to be?! *Environmental Sustainability*, 1 (2009) 83–88.
- Bugaje, I.M. (2006). Renewable Energy for Sustainable Development in Africa: A Review. *Renewable and Sustainable Reviews*. 10 (2006) 603–612. Available from Science Direct [2014, July 3].
- Chia – Yen Lee, Po – Cheng Chon, Che – Ming Chiang, and Chiu – Feng Liu. (2009). Sun Tracking systems: A review, *Sensors* 2009, 9 3875 – 3890; doi: 10.3390/S90503875. www.mdpi.com/journal/sensors [23 Feb 2013].
- Chong K.K. and Wong S.W. (2009). General formula for on axis sun-tracking system and its application in improving tracking accuracy of solar collector, *Sol. Energy*. 83 (2009) 298 – 305.
- Ciobanu D., Visa I., Jaliu C., and Burduhos B.G. (2010). Tracking system type linkage mechanisms. *Annals of DAAAM for 2010 and proceedings of the 21st International DAAM symposium*, 21 (1) ISSN 1726-9679, ISBN 978-3-901509-73-5. Ed. Kantalimo, DAAAM International, Vienna, Austria, EU 2010.
- Clifford M.J. and Eastwood D. (2004). Design of a novel passive solar tracker, *Sol. Energy*. 77 (2004) 269–280.
- Djeu D. (2004). Passive Solar Tracker for a Solar Concentrator, US Patent application. 20040112373, 2004. patents.com/us-20040112373.html – Cached [3rd April 2011].
- Ellegaard a, Arvidson, A., Nordstroöma, b, Mattias, Kalumiana, O, S., and Mwanza, C. (2004). Rural People Pay for Solar: Experiences from the Zambia PV-ESCO Project. *Renewable Energy*. 29 (8) (2004) 1251–1263.
- Elmer Z.K.G. (2006). Optimising solar tracking systems for solar cells, 4th Serbian – Hungarian Joint symposium on Intelligent systems. *SISY* (2006) 167-180.
- Eveleens I. E. Africa's first solar-panel plant supports Kenya's clean energy push, *AlertNet*, 23rd Nov 2011.
- Fluri T P. (2009). The Potential of Concentrating Solar Power in South Africa. *Energy Policy*, 37(2009) 5075–5080.
- Fthenakis, V. M. (2000). End-of-life management and recycling of PV modules. *Energy Policy*, 28 (14) (2000) 1051-1058.
- Full E. (2010). Appropriate Technologies in Mpala Village, Kenya: Solar, Water and Bamboo, [PPT] presentation www.princeton.edu/grandchallenges/health/...2010/Full_Eden_SOL.pptx [4th July 2011].
- Ghazali A. M. and Rahman A. M. A. (2012). The performance of three different solar panels for solar electricity applying solar tracking device under the Malaysian climate condition, *Energy and Environment Research*, 2 (1) (2012) 235 -243.
- He X., Wang B., Huang F., Zhu W. and Gao C. (2012). Solar Automatic tracker based on parallel mechanism, *J. Mech. & Elec. Eng.*, (01) (2012).
- Helwa N.H., Bahgat A.B.G., El Shafee A.M.R. and El Shenawy E.T. (2000). Maximum collectable energy by different solar tracking systems, *Energy Sources*, 22 (2000) 23-34.
- Hernandez C. (2011). The 19-year-old innovator revolutionizing solar energy systems. <http://www.smartplanet.com/blog/pure-genius/the-19-year-old-innovator-revolutionizing-solar-energy-systems/6436> [4th July 2011].
- Hitchcock. R.D. (1976). Passive solar tracking system for steerable Fresnal elements, US Patent. 3986021, 1976. www.patentstorm.us/patents/3986021/description.html – Cached [3rd April 2011].
- IEA see International Energy Agency.
- International Energy Agency, Renewables and Waste in Africa in 2008. http://www.iea.org/stats/renewdata.asp?COUNTRY_CODE=11 [30th June 2011].
- International Energy Agency IEA (2011). Energy for all: Financing access for the poor. *World Energy Outlook*, (2011) 11.
- Kalogirou S. (2007). Recent patents in solar energy collectors and applications, *Recent Pat. on Eng.* 1(1) (2007) 23-33.
- Kalogirou S. (2009). Thermal Performance, economic and environment life cycle analysis of thermo syphon solar water heaters. *Solar Energy*. 83 (1) (2009) 39-48.
- Kanyarusoke, K.E., Gryzagoridis, J. and Oliver, G. (2012a). Issues in solar tracking for sub-Sahara Africa, 1st Southern African Solar Energy Conference (SASEC), Stellenbosch, South Africa 21st-23rd May 2012.
- Kanyarusoke, K.E., Gryzagoridis, J. and Oliver, G. (2012b) Annual Energy Yields Prediction From Manufacturers' Photovoltaic Panel Specifications for Sub Sahara Africa, Proceedings of International

- Conference on Engineering and Applied Science 2012 (ICEAS 2012), 24th-27th July 2012. Beijing China. pp. 223-235.
- Karekezi S. (2002). Renewables in Africa – Meeting the Energy Needs of the Poor. *Energy Policy*. 30 (2002) 1059 -1069.
- Kelly N.A. and Gibson T.L. (2010). Optimizing the Photovoltaic Solar Energy Capture on Sunny and Cloudy Days Using a Solar Tracking System. http://www.cormusa.org/uploads/CORM_2010_presentation_Nelson_Kelly_Optimizing_the_Photovoltaic_Solar_Energy.pdf [30th June 2011].
- Kelly N.A. and Gibson T.L. (2012). Solar Photovoltaic output for cloudy conditions with a solar tracking system, US patent No. US 8,101,848B2 of Jan 24 2012.
- Kraak, A. (2005). Human Resources Development and the Skills Crisis in South Africa: The Need for a Multi-Pronged Strategy. *Journal of Education and Work*. 18(1) (2005) 57-83.
- Louchene A., Benmakhlouf A. and Chagai. (2007). Solar tracking system with Fuzzy reasoning applied to crisp sets, *Revue des Energies Renouvelables*. 10 (2) (2007) 231-240.
- Markvart T. (ed.). (2000). *Solar Electricity* 2nd ed. John Wiley & Sons, Chichester 2000.
- Martinez C.M.C. (2010). Bidirectional solar tracker, US Patent. 2010/0095955, 22nd April 2010.
- Meyer S.M. (2010). Two Axes solar tracking system, <http://www.freepatentsonline.com/y2010/0288062.html> [15th June 2012].
- Mills D. (2004). Advances in Solar thermal electricity Technology, *Sol Energy*. 76 (2004) 19 – 31.
- Mousazadeh H., Keyhani A., Javadi A., Mobli H., Abrinia K., and Sharifi A. (2009). A review of principle and sun-tracking methods for maximizing solar systems output, *J. Renew. & Sustain. Energy Rev*. 13 (2009) 1800 –1818.
- Mshelbwala S.A. (1996). Experimental investigation of a parabolic solar cooking device, Unpublished BEng Project. Mech. Eng. Dept. University of Maiduguri, Nigeria, 1996.
- Mulugetta, Y., Nheteb T. and Jacksona T. (2000). Photovoltaics in Zimbabwe: Lessons from the GEF Solar Project. *Energy Policy*. 28 (140) (2000) 1069–1080
- Murphy J.T. (2001). Making the energy transition in East Africa: Is Leapfrogging an alternative? *Technol. Forecast. & Soc. change*. 68 (2001) 173-193.
- Musa U., Sambo A.S. and Bala E.J. (1992). Design, Construction and Performance test of a parabolic concentrator cooker, Paper presented at the 1992 National Energy Forum, Sokoto.
- Mwithiga G. and Kigo S.N. (2006). Performance of a solar dryer with limited sun tracking capability, *J. Food Eng*. 74 (2006) 247–252.
- Oyetunji S.O., Sawhney R.I. and Aro I.O. (1989). Design, Construction and Estimation of performance of composite conical concentration, *Directory of Renewable Energy Research and Development activities in Nigeria*, SERC Sokoto. 1:12.
- Pauw, K., Oosthuizen, M., & Westhuizen, c. Van der. (2008). Graduate Unemployment in the Face of Skills Shortages: A Labour Market Paradox. *South African Journal of Economics*. 76 (2008) 1.
- Pegels, A. (2010). Renewable Energy in South Africa: Potentials, Barriers and Options for Support. *Energy Policy*. 38 (2010) 4945–4954.
- Pelemo D.A., Fasasi M.K., Owolabi S.A. and Shaniyi J.A. (2002a). Design, Construction and Performance of focusing type solar cooker, *Niger. J. Phys.*, 4 (2) (2002) 109-112.
- Pelemo D.A., Fasasi M.K., Owolabi S.A. and Shaniyi J.A. (2002b). Effective utilisation of solar energy for cooking, *Nig. J. Eng. Manag.* (NJEM), 3 (1) (2002) 13-18.
- Pelemo D.A., Fasasi M.K., Owolabi S.A. and Shaniyi J.A. (2003). Application of solar concentrator for water boiling and distillation, *Niger. J. Sol. Energy*, 14 (2003) 51-54.
- Peter, P. and Donnelly Jr., J. H. (2009). *Marketing Management* 9th ed. McGraw Hill, New York (2009).
- Poulek V. (1994). New low cost tracker, *Sol. Energy Mater. & Sol. Cells*, 33 (1994) 287-291.
- Rabinowitz M. (2011). Tracking and focusing adjustable fresnel lens array solar collector, US Patent. 7960641 B2. www.uspto.gov/web/patents/patog/.../US07960641-20110614.html – Cached [2nd August 2011].
- Rahman S., Ferdaus R. A., Mannan M. A. and Mohammed M. A. (2013). Design and Implementation of a dual axis solar tracking system. *Am. Acad. & Scholarly Res. J*. 5 (1) (2013) 47 – 54.
- Rizk J. and Chaiko Y. Solar Tracking system. (2008). More efficient use of solar panels, *World Acad. of Sci. and Techno*, 28 (28) (2008) 313-315.
- Seme S., Stumberger G. and Vorsic J. (2011). Maximum efficiency trajectories of a two – axis sun tracking system determined considering tracking system consumption, *IEEE Transactions on Power Electronics*, 26(4) (2011) 1280 – 1290.
- Slama R.B. and Combarnous M. (2011). Study of Orange peels drying kinetics and development of a solar dryer by forced convection, *Sol. Energy*. 85 (2011) 570-578.
- Sobamowo M.G., Kamiyo O.M, Ojolo S. J. and Ogundeko I.A. (2012). Design and Development of a Photovoltaic-Powered DC Refrigerator System with an Incorporated Solar Tracker, 1st Southern African Solar Energy Conference (SASEC), Stellenbosch, South Africa 21st-23rd May 2012.
- Sobolewski. (2011). Roof mounted double axis tracker, US Patent. 20110120447, 26th May 2011.
- Solar Buzz (2012). Solar Energy Market Growth. <http://www.solarbuzz.com/facts-and-figures/markets-growth/market-growth> [7th April 2012].
- Sovacool B. K., D’Agostino A. D. and Bambawale, M. J. (2011). The Socio-technical Barriers to Solar Home Systems (SHS) in Papua New Guinea: “Choosing pigs, prostitutes, and poker chips over panels. *Energy Policy*. 39 (3) (2011) 1532–1542
- Suleiman A.K., Bajpai A.C. and Sulaiman A.T. (1989). Design, Fabrication and Testing of a low-cost cylindrical collector for steam generation, *Directory of Renewable Energy Research and Development Activities in Nigeria*, SERC, Sokoto, 1989, pp. 1-13.

- Tina G.M. and Gagliano S. (2011). Probabilistic modeling of hybrid solar/wind power with solar tracking system, *Renew. Energy*, 36 (2011) 1719 –1727.
- Tomson T. (2008). Discrete two positional tracking of solar collectors, *Renewable Energy*. 33 (2008) 400 – 405.
- United Nations Energy Agency. (2007). Energy for Sustainable Development: Policy Options for Africa. Vol. 2008.
- United Nations (2014). Division for Sustainable Development. Department of Economic and Social Affairs. A Survey of International Activities in Rural Energy Access and Electrification.
- United Nations Economic Commission for Africa. (2006). African Regional Implementation review for the 14th Session of the Commission on Sustainable Development (CSD-14) (2006). Report on “Energy for Sustainable Development”. United Nations Economic Commission on behalf of the Joint Secretariat UNECA, UNEP, UNIDO, UNDP, ADB and NEPAD Secretariat.
- Vanek F. M., Albright L. D. and Angenent L.T. (2012). *Energy Systems Engineering: Evaluation and Implementation* 2nd ed. New York, McGraw Hill, (2012) 49-71.
- Winston R. (2001). Solar concentrators, In Gordon, J. (ed.) *Solar Energy: The state of the art – ISES position papers*. James and James Science Publishers, London, 2001, pp. 357-436.
- Wu Chun-Sheng, Wang Yi-Bo, Liu Si-yang, Peng Yan – Chang, and Xu Hong – Hua. (2008). Study on Automatic Sun-Tracking technology in PV Generation. *DRPT 2008*, 6-9 April 2008, Nanjing, China. *IEEEExplore* 2586 – 2591.
- Yi J-H. and Hwang W-C. (2009). Solar tracking device with springs, US Patent. 7607427 B2, 2009. www.wikipatents.com/...Patent-7607427/solar-tracking-device-with-... – Cached) [3rd April 2011].
- Zerlaut G.A. and Heiskell R.F. (1977). Solar Tracking device, US Patent. 4031385, 21st June 1977.
- Zomeworks. (n.d.). PV trackers. <http://zomeworks.com/products/pv-trackers/how-trackers-work> [3rd April 2011].

Received 28 July 2014; revised 26 December 2014