

# Investigation of common-mode voltage and ground leakage current of grid-connected transformerless PV inverter topology

Atanda K Raji

Mohamed T E Kahn

Centre for Distributed Power Electronics Systems, Cape Peninsula University of Technology, South Africa

## Abstract

*The problems of increasing electricity demand by the unabated population and economy growth can be solved by employing sustainable distributed generation technologies. Conventional primary energy sources such as coal, liquid hydrocarbons' and natural gasses create environmental degradation and energy security problems. Even though the cost of solar energy is zero, the same cannot be said of a solar energy system. The system cost especially the initial capital investment has been hindering the rapid deployment of solar energy systems. One way of reducing the system cost of a solar energy system is to look into the constituent components and see where cost can be reduced without compromising the system efficiency and human safety. Eliminating the isolation transformer reduces the cost and increases the system overall efficiency. However, the galvanic connection between the PV array and the utility grid creates a safety problem for people and system equipment. We present a simplified model for the investigation of the common mode voltage and ground leakage current that can lead to electromagnetic interference. The leakage current level is used for the determination of the suitability of the investigated PV inverter topology for grid connection without isolation transformer.*

*Keywords: common-mode voltage, grid-connected transformerless PV inverter topology; ground leakage current*

## Introduction

The problems of increasing electricity demand by the unabated population growth can be solved by employing sustainable distributed generation technologies. Conventional primary energy sources such as coal, liquid hydrocarbons' and natural gasses create environmental degradation and energy security problems (Binal, 2000). Alternative energy sources such as wind, solar, wave, tidal, geothermal and ocean are renewable sources that are sustainable and environmentally friendly. Amongst these renewables, solar energy is in pole position to be adopted as distributed generation integrated into a low voltage system. The abundance and everywhere availability of solar energy provides easy site for system setup, reduced transmission losses and eliminate utility grid extension cost for very low load centres such as remote villages (Bull & Billman, 2000)

Even though the cost of solar energy is zero, the same cannot be said of a solar energy system. The system cost especially the initial capital investment has been hindering the rapid deployment of a solar energy system (Bouffard & Kirschen, 2008). Many governments around the world have provided incentives and subsidies to promote fast adoption of renewable energy systems. However, such policy is not sustainable in the longer terms and it is highly dynamic (Winkler, 2005).

One way of reducing the system cost of a solar energy system is to look into the constituent components and see where cost can be reduced without compromising the system and human safety (Arnam & Zhong, 1997). 25% of the solar system cost constitutes the inverter system cost out of which 15% is the cost of the transformer that is used to isolate the PV array from the AC grid system for

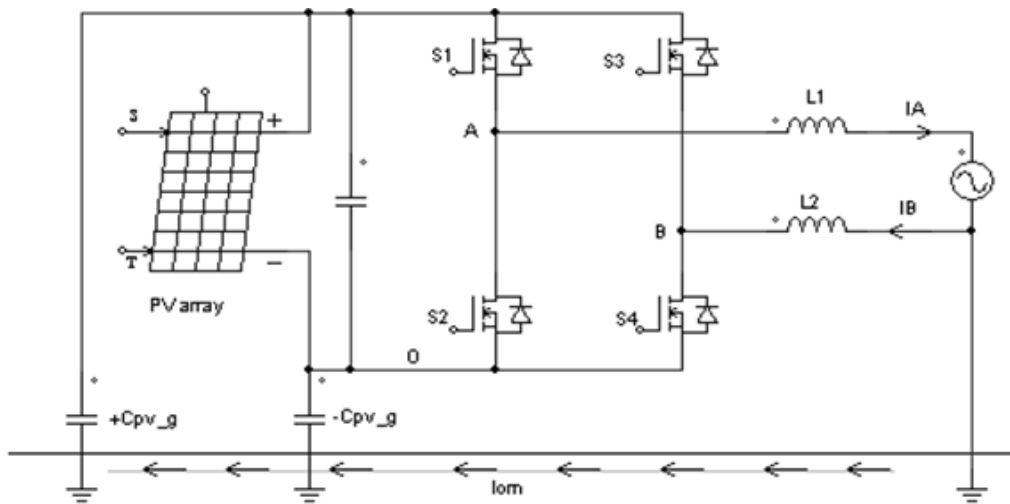

Figure 1: H bridge grid connected PV module

safety reasons. The percentage contribution of the inverter system cost may increase in longer terms as the cost of PV module continues to decrease. Eliminating the isolation transformer reduces the cost and increases the system overall efficiency. However, the galvanic connection between the PV array and the utility grid creates a safety problem for people and system equipment (IEEE Standard 1547, 2003).

The PV array parasitic capacitance between the PV array and the ground causes leakage current to flow (Barater et al., 2009). Many PV inverter topologies with different switching strategies have been proposed in the technical literature to mitigate the problem of common-mode voltage (CMV) and ground leakage current (Francke et al., 2010; Photong et al., 2010).

The next section presents the analysis of a simplified model suitable for the investigation of common-mode voltage and ground leakage current for a conventional full bridge inverter topology with unipolar switching strategy. Section three models, simulates the presented model using PSIM software and presents the simulation results. Conclusion of the work is presented in the final section.

### Simplified model for CMV and GLC

The full bridge inverter topology used in this work is presented in Figure 1. Switches S1/S4 and S3/S2 switched with unipolar modulation strategy. An L output filter is used to ensure that the injected AC current complies with the harmonics requirements stated in the grid codes (Azri & Rahim, 2011).

In the full bridge circuit shown in Figure 1, voltages  $V_{AO}$  and  $V_{BO}$  are controlled by the four switches S1, S2, S3 and S4. The principle of superposition is used for the analysis. Each of the voltage sources is considered acting alone and the total effect of all is obtained from the algebraic sum of the individual current produced by each source acting alone.

PV parasitic capacitance value of 100nF is used for the investigation (Bassoon, 2018). The parasitic capacitance depends on such factors as weather, PV cell technology, distance between the PV cells and the frame etc. (Azri & Rahim, 2011; Arajo et al., 2010; Lopez et al., 2007; Photong, 2010).

When the upper switch is on, the corresponding voltage is equal to  $V_{DC}$  while the lower switch corresponding voltage is zero (reference O). Therefore, we can replace the DC bus and switches with two PWM voltage sources as shown in Figure 2.

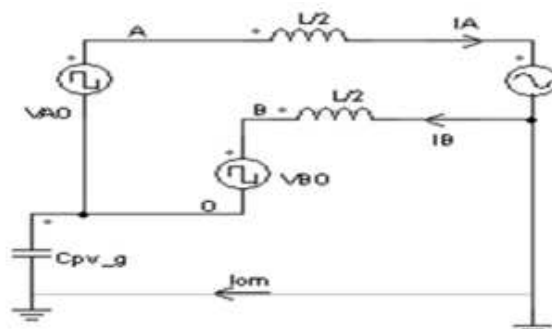

Figure 2: Equivalent common-mode currents

According to the superposition theorem, the total leakage current is the sum of the currents generated by the grid and the two PWM voltage sources. Figure 3 shows the leakage current generated by the grid. The leakage current generated by the two PWM voltage sources is shown in Figure 4.

As shown in Figure 3, the leakage current  $i_{cm1}$  generated by the grid can be given as:

$$i_{cm1} = \frac{-\frac{1}{2} jv_{grid}}{-\frac{1}{4} \omega_{grid} L + \frac{1}{\omega_{grid} C_{pv\_g}}} \quad (1)$$

As shown in Figure 4, the leakage  $i_{cm2}$  and  $i_{cm3}$  generated by the PWM voltage sources can be given as:

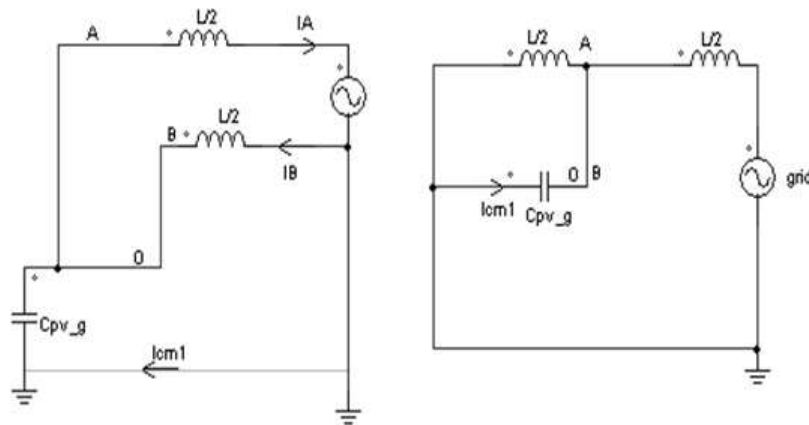

Figure 3: Generated grid leakage currents

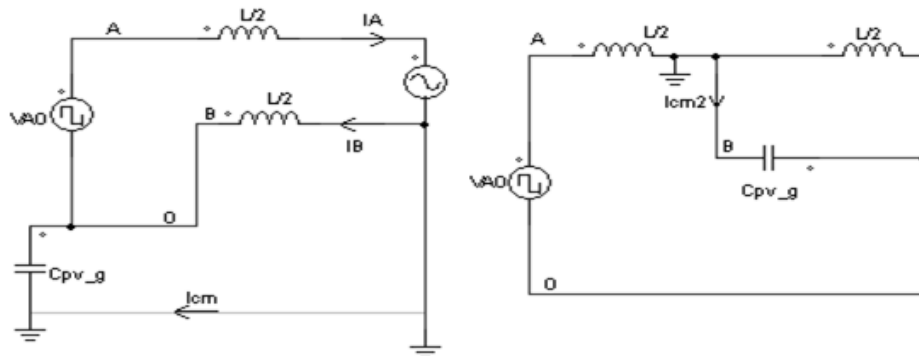

Figure 4: Generated PWM for each inverter leg

$$i_{cm2} = \frac{\frac{1}{2} jv_{AO}}{-\frac{1}{4} \omega L + \frac{1}{\omega C_{pv\_g}}} \quad (2)$$

$$i_{cm3} = \frac{\frac{1}{2} jv_{BO}}{-\frac{1}{4} \omega L + \frac{1}{\omega C_{pv\_g}}} \quad (3)$$

Compared to the switching frequency, the grid frequency is low, thus  $I_{cm1}$  can be ignored. In literature cases, the leakage current caused by the grid is not discussed, but it truly exists even when the common mode voltage is kept constant during all commutation states.

Combining equations 2 and 3, the total leakage current  $i_{cm}$  and common mode voltage  $v_{cm}$  are given in equations 4 and 5 respectively.

$$i_{cm} = \frac{jv_{cm}}{-\frac{1}{4} \omega_{cm} + \frac{1}{\omega_{cm} C_{pv\_g}}} \quad (4)$$

$$v_{cm} = \frac{1}{2} (v_{AO} + v_{BO}) \quad (5)$$

According to equation 5, the equivalent circuit model of common mode leakage current can be obtained as shown in Figure 5.

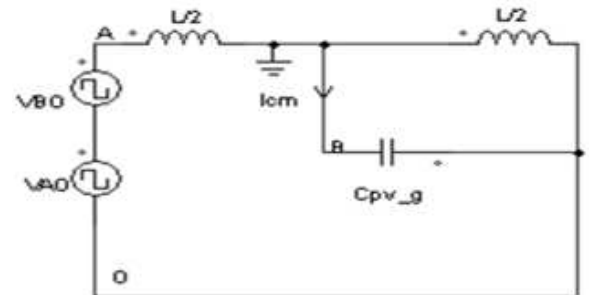

Figure 5: Combined inverter leg generated common-mode currents

As shown in Figure 5 it is concluded that if the common mode voltage is kept constant during all the commutation states, leakage current could be restricted to nearly zero (assuming that the leakage current contribute by the grid is negligible).

### Simulations and results

The inverter output voltage is shown in Figure 6 changing from positive peak value to zero and then to negative peak values. The three voltage vector states enable the topology to be switched with half the switching frequency with the same component parameters as a full bridge with bipolar switching strategy. This provides the advantage of lower filter requirements and reduce the core loss of the filter inductor.

The common mode voltage imposed on the PV array parasitic capacitance is shown in Figure 7.

The PV array terminal voltage across the PV array parasitic capacitance is shown in Figure 8 to contain harmonics of switching frequency.

The leakage current through the PV array parasitic capacitance is shown in Figure 9. It contains

harmonics of the switching frequency. The peak value of the ground leakage current is 3,552 A and the average value is 1,164 A while the root mean square value is 1,345 A.

Figure 10 shows the FFT of the ground leakage

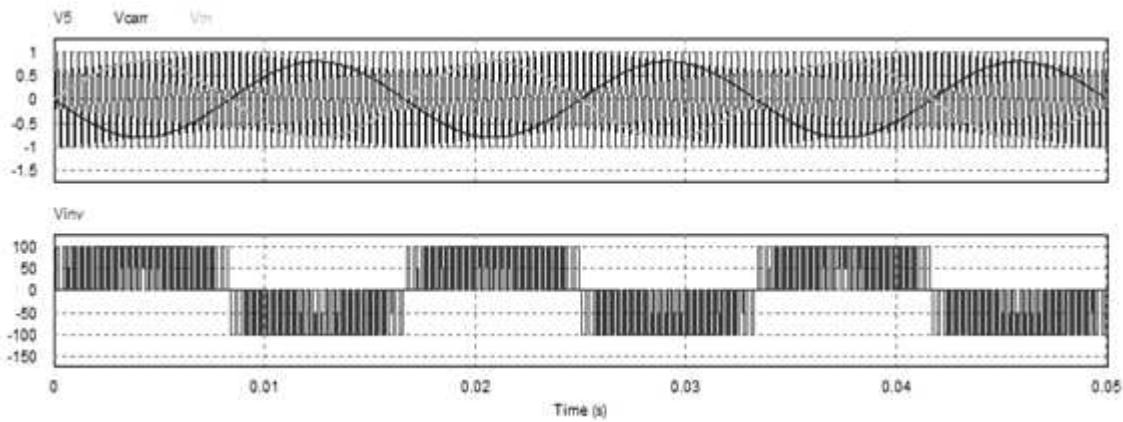

Figure 6: Unipolar inverter output voltage

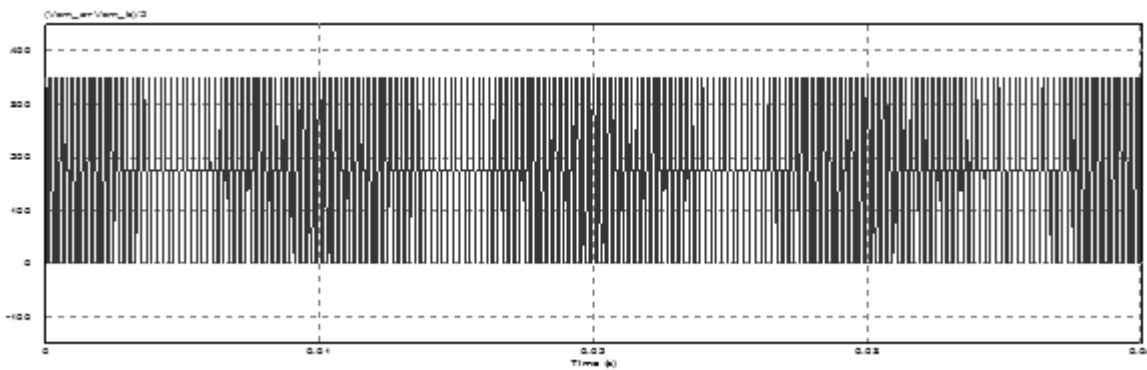

Figure 7: Common mode voltage

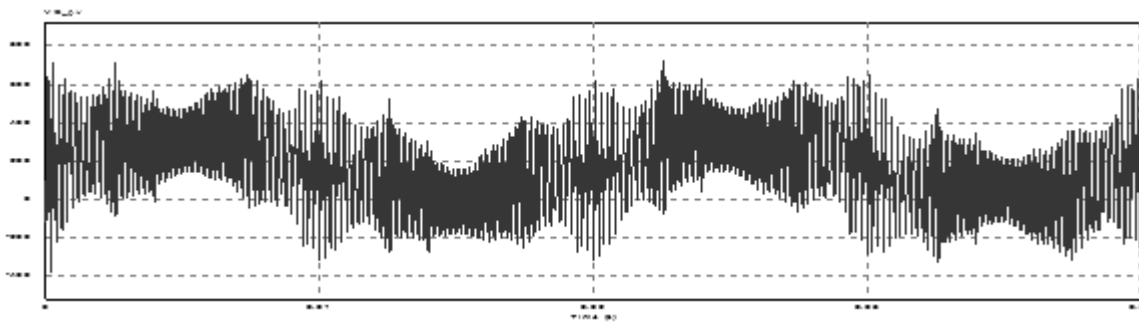

Figure 8: PV array terminal voltage

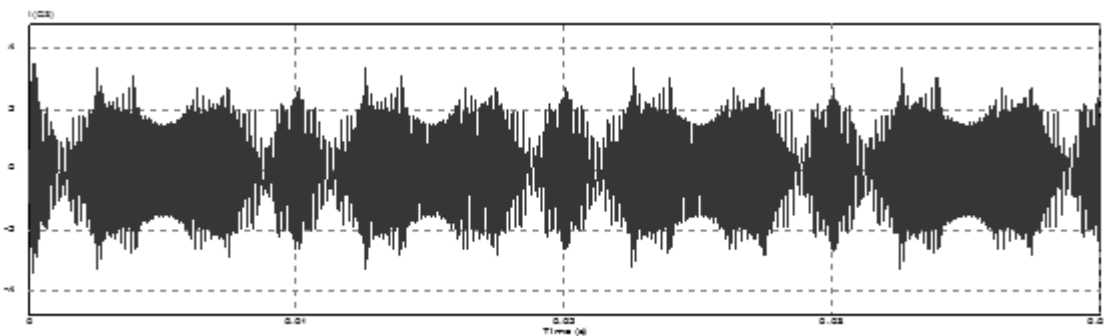
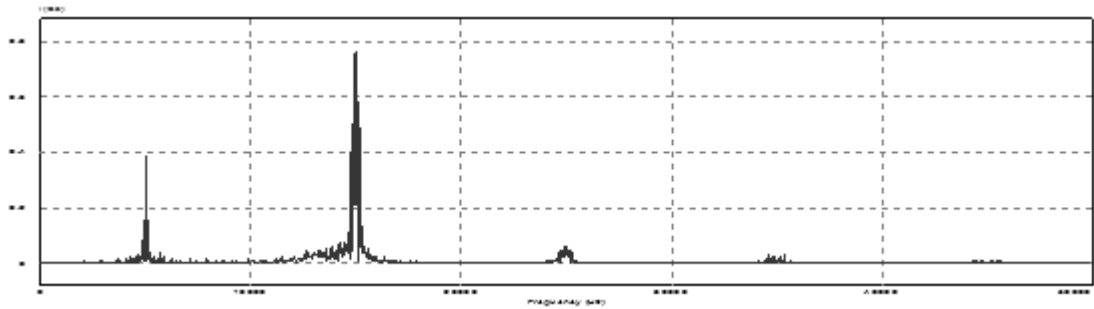

Figure 9: Ground leakage current



**Figure 10: FFT of the ground leakage current of the simulated PV inverter topology**

current of the simulated PV inverter topology.

### Conclusion

A simplified model of a grid-connected transformerless PV inverter topology for the investigation of the common-mode voltage and ground leakage current is presented in this paper.

A conventional full bridge (FB) inverter topology with unipolar switching is used as an example to carry out the investigation.

Based on the simulation results, the FB with unipolar switching is not acceptable for PV transformerless configuration because it does not comply with the safety requirement of VDE 0126-1-1. However, similar investigation was carried out of same topology but with bipolar switching scheme and found to be compliant with respect to VDE 0126-1-1 safety requirements. This methodology can be extended to other transformerless topologies for grid-tied technical requirements compliance test. The benefit of reduced system cost and increased energy efficiency of grid connected transformerless PV topology will accelerate solar energy system deployment in developing countries such as South Africa.

### References

- Arajo S., V., Zacharias P., and Mallwitz R., (2010). Highly Efficient Single-Phase Transformerless Inverter for Grid-Connected Photovoltaic Systems, IEEE Transaction on Industrial Electronics, Vol. 57, no. 9, pp. 3118-3128.
- Arman M. F and Zhong L., (1997). A new transformerless, photovoltaic array to utility grid interconnection, in Proceeding International Conference in Power Electronics and Drive Systems, May 26-29, 1997, vol. 1, pp. 139-143.
- Azri M. and Rahim N. A., (2011). Design Analysis of Low-Pass Passive Filter in Single-Phase Grid-Connected Transformerless Inverter, IEEE First Conference on Clean Energy and Technology CET, pp. 348-353.
- Barater D., Buticchi G, Crinto A. S., Franceschini and Lerezani E (2009), A new proposal for ground leakage current reduction in Transformerless Grid-Connected Converters for Photovoltaic Plants. Industrial Electronics, IECON 09. 35th Annual Conference of IEEE pp.4531-4536.
- Bassoon T. S., (2008). High-Penetration, Grid-Connected Photovoltaic Technology Codes and Standards, 33rd IEEE Photovoltaic Specialists Conference San Diego, California, pp. 1-4.
- Bimal K. B. (2000) Energy, Environment, and Advances in Power Electronics, IEEE Transaction on Power Electronics, Vol. 15, No. 4, pp. 688-701.
- Bouffard F and Kirschen D. S., (2008). Centralized and Distributed electricity systems, Energy Policy, Vol. 36, pp. 4504-458.
- Bull S R and Billman L. L., (2000). Renewable Energy: Ready to meet Its Promise?, The Center for Strategic and International Studies and International Studies and the Massachusetts Institute of Technology, The Washington Quarterly, 23:1, pp. 229-244.
- Dicorato M. and Travato G. F., (2008). Environmental-concerned energy planning using energy-efficiency and distributed-generation facilities, Renewable Energy, Vol. 33, pp. 1297-1313
- Franke W.-Toke, Oestreich N. and Fuchs F. W., (2010), Comparison of Transformerless Converter Topologies for Photovoltaic Applications concerning Efficiency and Mechanical Volume, pp. 724-729
- IEEE Standard 1547, (2003). IEEE Standard for Interconnecting Distributed Energy Resources with Electric Power System, 28 July, pp.1-16.
- Kerekes T, R Teodorescu and U Borup, (2007). Transformerless Photovoltaic Inverters Connected to the Grid, Applied Power Electronics Conference, APEC 2007 - Twenty Second Annual IEEE, pp.1733-1737
- Lopez O., Teodorescu R., Freijedo F and DovalGandoy J., (2007). Leakage current evaluation of a single phase transformerless PV inverter connected to the grid, Applied Power Electronics Conference, APEC 2007 - Twenty Second Annual IEEE , pp. 907-912.
- Photong C., Klumpner C and Wheeler P., (2010). Evaluation of Single-Stage Power Converter Topologies for Grid-Connected Photovoltaic, Industrial Technology (ICIT), IEEE International Conference on, pp.1161-1168.
- Winkler, H. (2005), Renewable energy policy in South Africa: policy options for electricity, Energy Policy, Vol. 33, pp. 27-38.

*Received 5 August 2012; revised 14 February 2015*