

A PV power supply module for a portable Cubesat satellite ground station

Gustave M Mwanyasi

Technical University of Mombasa, Mombasa, Kenya

Marco Adonis

Cape Peninsula University of Technology, Cape Town, South Africa

Abstract

This research focuses on the problem of powering a remote and mobile satellite ground station, where utility power is unavailable. It focuses on the use of photovoltaic energy, which is now widely accepted as an alternative source of energy. However, PV suffers from low conversion efficiency, non-linear I-V characteristics, which depend on temperature changes and the earth rotation. The research focuses on accurate determination of the ground station power budget whose total power demand involves an azimuth and rotator function and a current which varies depending on the stages of communication with the satellite. The power budget is used to determine the size, the ratings of solar generators, batteries and the system components. With the aid of a power logger, the PV voltage, the battery voltage, the AC voltage and PV power output is analysed for varying satellite loads. The data is analysed by taking into account the solar irradiation level on the day of measurement and the percentage cloud cover. This method is found to improve the reliability and can be adopted to improve reliability of standalone PV systems. The results are vital in PV power management and design.

Keywords: PV standalone power system, CubeSat satellite ground station, solar generator

1. Introduction

The mobile satellite ground station is essential with the increased use of satellite technology for communication, education and for the radio amateur enthusiast. There is a need to extend this technology to the remotest parts of Africa, but many of these areas lack a connection to the electrical grid. This research is an attempt to solve this problem by developing a PV standalone module ideal for a portable satellite ground station.

Kaldelis et al., (2010) observe that 90% of today's installed PV power is standalone with 80% being used in communication and water pumping and, while the initial cost of a PV array is higher than a diesel generator, it is maintenance free, has no fuel cost, no replacement of parts, and lasts up to 20 years. While the diesel generator lasts for only 10 years. They conclude that PV standalone with a battery is efficient up to 1kW load. This makes it ideal for the ground station application since its demand is about 600W. The research addresses lack of reliability of the systems due to poor sizing of the components. A larger solar panel than the battery will result in wastage of power as heat and an unnecessarily high cost of the energy produced, while a smaller panel makes the installation unreliable. The research attempts to use the power demand of the load, to come up with equivalent size of panels, components and battery to design a reliable and portable PV standalone system.

1.1 South Africa PV power production outlook

The PV industry scenario in the world is as follows: The USA completed a 14MW plant in 2007 and Spain a 20MW plant in the same year. The scenario in Africa is different with its PV systems being mostly standalone systems, having a production capacity of less than 1MW. This finds application in rural electrification, health centres, and rural households. The same scenario is replicated in Bangladesh, Kenya, and Sri-Lanka. South Africa has this form of PV system with an estimated capacity of 21MW. Bhandari and Stadler (2011) observe that, there has been a rapid growth in production of low cost photovoltaic components. This coupled with steps taken by some governments to subsidise the cost of PV installation and the initiative by some countries to purchase PV energy connected to the grid has made photovoltaic energy economically viable.

South Africa is credited with having some of the highest amount of irradiation globally with Northern Cape Province having the highest solar resource in the country. It has 30% higher irradiation levels than the best sites in Spain. Upington in the Northern Cape has more than 6.5kW/m²/day average global irradiation. Other areas include the Free State, North West, Limpopo, and interior parts of Western Cape and the Eastern Cape. Thus solar potential in South Africa is considerable.

The South African Department of Energy conducted a pre-feasibility study, through an MOU between the government and the Clinton Climatic Initiative in October 2009, with the aim of exploring the potential of a solar park. This study recommended one of the potential sites as Upington in the Northern Cape. This proposed site has the potential of producing up to 5000MW of electrical power.

1.2 Load capability of PV standalone system

Kaldelis *et al.*, (2010) states that there will be a drastic increase in the market of a PV standalone system in developing countries in future, especially in rural electrification. They note the following trend:

- Currently it can be estimated that 90% of today's installed PV power is stand alone.
- Up until 1997, about 640MWp of PV power had been installed.
- 80% of all PV stand-alone power installed is used in communication, water pumping and domestic power supply.

The German Solar Energy Society, Ecofys (2005), notes the following economic considerations in deciding on a power system:

- *Portable throw away batteries:* There will always be a market for portable primary throw away batteries for the lowest levels of energy demands e.g. watches, torches and radios. Good

rechargeable batteries with a PV battery charger will prove cheaper than disposable batteries over a few years.

- *Domestic power supplies:* For on-off domestic supplies for lighting, TV, fans etc., a battery based supply charged by a PV or wind is likely to be the most cost effective. If occasional power peaks occur, a backup generator can be considered.
- *A small village or a number of domestic supplies:* The economic choice is either individual based battery units (solar home systems or commercial battery charging) or a centralised scheme made up of a PV plant, diesel generator or micro-hydro.
- *Remote water pumping:* The economic choice can be a PV system, wind pump or diesel.
- *A large village:* Where a hundred of kW is required. The economic choice is between micro-hydro, diesel or extending the grid.

From this analysis it can be concluded that the most economic load of a PV system is limited by the size of the load to be powered.

2. Challenges of PV implementation

The most commonly used solar cells currently have a light to electricity conversion efficiency of only 16%. This poses a challenge to this research as the CubeSat Satellite Ground Station load is variable and needs quite large power during tracking and downloading of data within a specified time limit. This presents a challenge in accurate determination of the power budget of the ground station and the rating of the solar generator capable of providing this power.

2.1 Effect of solar insolation

The amount of sunshine received at any time during the day is called solar irradiance, light intensity, solar flux, solar intensity, solar irradiance or irradiation. Solar irradiance varies throughout the day due to the movement of the sun and the clouds. The amount of irradiance measured in a day over a period of time is called daily solar insolation. Its units are watts per square meter (W/m²) or milliwatts per square centimetre (mW/cm²). On a very clear day, the irradiance reaching a surface that faces the sun is approximately equal to 1000W/m². This is also represented by light spectral AM1.5 (Robert, 1991). As solar irradiance plays a vital role in the output power of the PV system, but how will the solar insolation level affect the operation of the designed system? What level of insolation results in efficient operation? How will the system operate in other insolation levels?

2.2 Temperature effects

Temperature rise and fall has a significant effect on

the PV output. A rise in temperature reduces the performance of the array. Drop in temperature increases the voltage output. The temperature of the site of operation is taken into account.

2.3 Insolation and current effect on the system

The electrical current generated by a module is directly proportional to the irradiance reaching it. This means for maximum current output, the sun should be overhead the module and the module should be placed horizontally. If the position of the sun in the sky is about 30 degrees, the module should be tilted at an angle of 60 degrees from the horizontal for maximum current. As the sun moves irradiance changes thus the generated current varies throughout the day. The charging current is highest at midday and lowest in the evening. This means highest charging of the battery happens in the middle of the day. Clouds cover affects the irradiance and the charging current. During cloudy days, little current is generated as the irradiance reaching the earth is reduced. When there is a thin layer of cloud the irradiance might be 300W/m^2 , with thick cloud cover this is reduced to 100W/m^2 and the current will be zero with very little charging (Robert, 1991). The challenge is to determine the effect of the sun movement and the percentage cloud cover on the designed PV system.

2.4 PV components power rating effect

A photovoltaic system consists of PV components sized and connected to work in harmony. The components making up a PV system are:

- A solar generator with a mechanical support
- Storage (batteries)
- Power conditioning, and control equipment

PV systems rely on the irradiation of the solar energy on the PV cell to generate electricity. Without this irradiation, no energy is generated. To allow for continual supply of energy to the loads at night and during cloudy seasons, energy is stored. A battery is used for this purpose. Other elements used with PV systems include:

- Power conditioning elements; these are used to condition the DC voltage from the solar cell to AC.
- A PV system depends on irradiation, which is very variable. The control equipment boosts the solar energy and reduces this variation. They interface different parts of the system to the DC load.

In order to increase the reliability of the system, there is a need to design size and carry out proper installation and termination. Markvat (2008) observes that reliability of solar energy plays a crucial part in its design. Most decisions during design

consider maximum power production and reliability.

The challenge for this project is to determine the CubeSat ground station power budget, followed by the determination of the rating of the solar panels and the PV components capable of carrying this load, taking into consideration the cost of the PV energy produced.

3. Methodology

3.1 The satellite ground station load

Figure 1 shows the satellite ground station equipments. The azimuth/rotator is powered from 227VAC. It's used during tracking and downloading data. The communication equipment includes the transceiver, RF line control unit, receiver and the microphones. These are powered from a 13.8VDC, 0-30A power supply. The PC is powered from 227VAC. Figure 2 indicates the antennas at the CPUT satellite ground station use during tracking and downloading of data. This is the overall load to be powered by the PV power module.

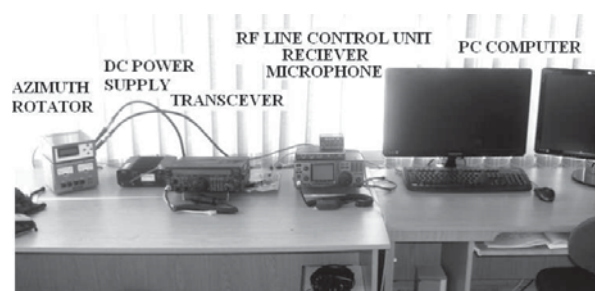

Figure 1: Ground station equipment



Figure 2: Antennae for satellite tracking

3.2 Ground station power consumption determination

3.2.1 Azimuth/ rotator maximum power

The power consumption of the azimuth/rotator is determined by logging the power while operating it up to its full operation capacity, when both Azimuth and controller functions are at maximum. Table 1 shows the maximum current and power measurements.

Table 1: Azimuth/Rotator power measurement

Time of day	Elapsed	Voltage (V)	Current (A)	Power (W)
11:44:16	0.02	227	5.51	9.82
11:44:21	0.02	227	5.52	9.93
11:44:26	0.02	227	0.00	8.31
11:44:31	0.02	227	5.50	9.93
11:44:36	0.02	227	5.54	9.93
11:44:41	0.02	227	5.56	100
11:44:46	0.02	227	5.57	101
11:44:51	0.02	227	5.60	100
11:44:56	0.02	227	5.63	102

3.2.2 Communication equipment power

Table 2 shows the variation of the current, voltage and the resultant power output during tracking and downloading of data from a satellite.

Table 2: Power output of communication function

Current (A)	Voltage (V)	Power (W)
0	13.8	0
5	13.8	69W
10	13.8	138W
15	13.8	207W
20	13.8	276W
25	13.8	345W
30	13.8	414W

3.2.3 Total ground station power budget

From the described analysis, the power budget can further be derived as shown in Table 3, assuming maximum power consumption during any time of the elements operation.

Table 3: The resultant power budget

Equipment	Power rating	Time estimate	kWh
Communication equipment	414W	1 hour/day	414Wh
Rotator/Azimuth	102/5min	5 mins (steps)	102Wh
PC(Computer)	60W	1 hour/day	60 W
Total			576Wh

3.3 Ground station power consumption topology

From the analysis of Table 1, Table 2 and the PC power consumption, the interconnection of the Ground Station equipments and the resultant power topology can be represented by Figure 3.

3.4 The power consumption structure

Again using Tables 1 and 2 and the PC power consumption, the power topology is further broken as illustrated in Tables 4 and 5 to allow flexibility in data analysis.

Table 4: Breakdown of ground station power use

PC computer	Azimuth / controller	Communication equipments	Total power
60W	0	0	60W
60W	49.7W	69W	178.7W
60W	50.7W	138W	248.7W
60W	88.1W	207W	350.1W
60W	99.3W	276W	435.3W
60W	101W	345W	506W
60W	102W	414W	576W

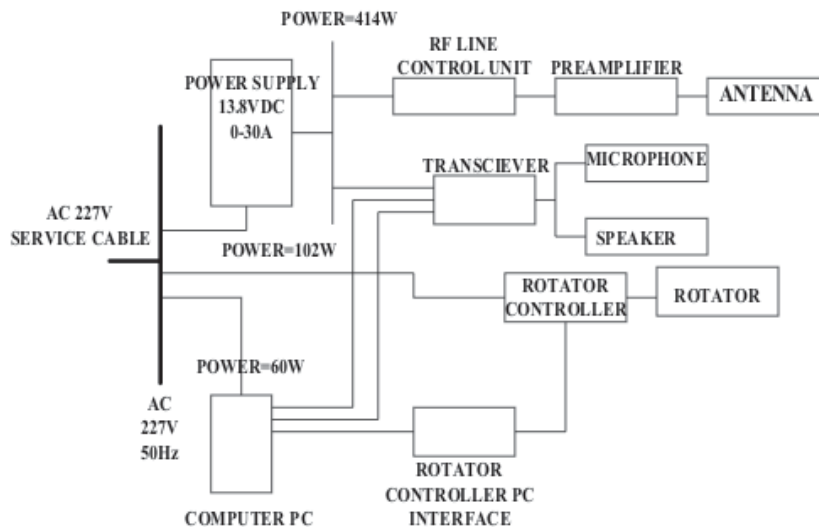

Figure 3: The resultant power topology

Table 5: Power consumption according to operation

Power rating	Ground station operation function
60W-178.7W	PC computer and communication equipment
178.8W-248.8W	Computer, communication and rotation functions
248.8W-300W	All functions (tracking and downloading of data)
300W-576W	All functions(tracking and downloading of data)

3.5 The equivalent PV system topology

From Figure 3, the equivalent PV topology is designed as in Figure 4. The ratings and numbers of the components are determined focusing on the Ground Station power budget. The following formulas are used:

$$\text{Module daily output } (d/o) = \frac{I_M \times I_R \times 12V}{F_1 \times F_2} \quad (1)$$

Where

I_M = Module maximum power point current

I_R = Daily irradiation current

F_1 = Temperature correction factor

F_2 = Tilt angle correction factor

$$\text{Number of modules} = \frac{P_b (Wh / day) \times 100}{d / o \times b_t (\%)} \quad (2)$$

Where

$P_b (Wh / day)$ = Power budget

d / o = Module daily output

b_t = Battery charging efficiency (%)

$$\text{Battery usable capacity/day} = \frac{P_b (Wh / day) \times P_{st}}{V_m} \quad (3)$$

Where

$P_b (Wh / day)$ = Power budget

V_M = Total solar array output

$$\text{Number of batteries} = \frac{U_c (Ah) \times 100}{N_c \times D_{ch}} \quad (4)$$

Where

U_c = Battery daily usable capacity

N_c = Battery nominal capacity

D_{ch} = Depth of discharge allowed

All other elements are also sized with reference to the ground station power budget. Table 6 is a list

of components and their specification ideal for this project.

Table 6: List of the components and specification

Component	Technical specification	Units
Step-down Buck converter	20-28Vdc, 13.65-13.8Vdc, 40A	1unit
Sun module 50w, mono/R5A,	Voc 21.0v, Isc 3.40A Vmpp 16.2, Impp 3.10A	4units
Steca Solarix (Gamma) 12A	12/24, 12A Regulator with LED	1unit
Excis 12v 102Ah maintenance free battery	Cagrids and plates, glass backed separators	2units
Cotek 300w 24v pure sine wave inverter	S300-224220/230/240, start on demand	1unit
Earth leakage circuit breaker	25A 30Ma 2P DID overload	1unit
Cylindrical fuses	20mA-500v 100KA 10X38mm	2units
Circuit breakers	10Amp-AC	1unit
Econo fuse holder for cylindrical fuses	2P 32A-500V fuse holder 10X38mm	1unit
Blocking diode at life battery terminals	12Amps or 6 Amps rating	2 units
Wire PVC 1.5mmsq round white p/m	3 core cabtyre	8M
Plug/3pin /British standard	Plug top 13A	4 units
Socket outlets	13 Amp 3 Pin plug	6 units

4. Investigation and measurements

To determine the capability of the PV system logging in is done for a load representing a specific function of the Ground station. The time for logging is 1 hour, which represents time for two satellites downloads. The basis for logger measurements takes into account the following power based formulas:

$$V_{RMS} = \sqrt{\frac{1}{T} \int v^2 dt} \quad (5)$$

$$I_{RMS} = \sqrt{\frac{1}{T} \int i^2 dt} \quad (6)$$

$$THD = \frac{\sqrt{\sum_{n=2}^{40} (V_h)^2}}{V1} \times 100 \quad (7)$$

THD=Total harmonic distortion

The solar cell is the main converter of photon energy to electric energy. The cells are connected to

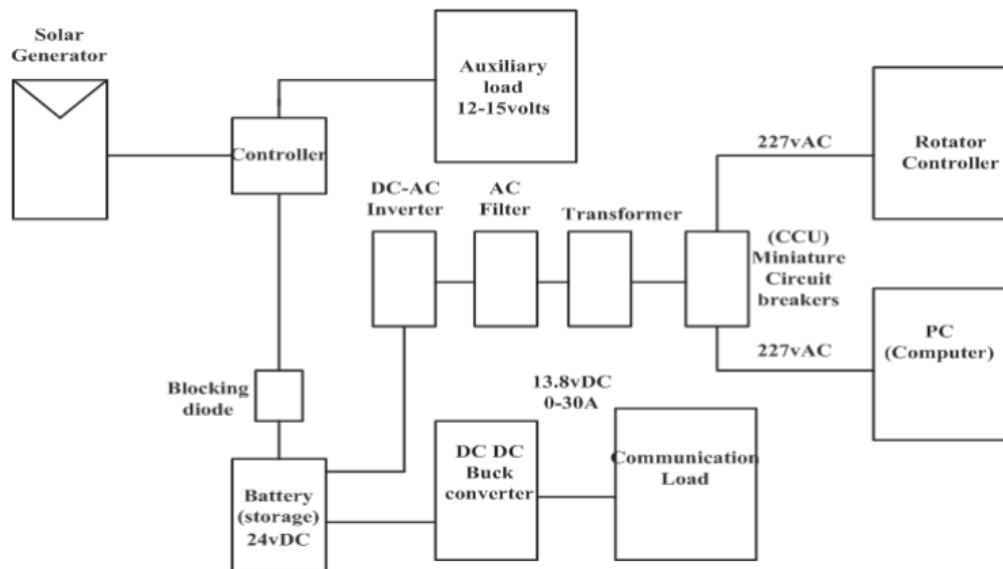

Figure 4: The designed PV topology

form solar panels. The panels are connected in parallel and placed at an angle of 45° . Their production is about 200Wp.

The PV energy control centre consists of circuit breakers for circuit protection, charge controllers, inverters, step down DC/DC converters and the batteries. The incandescent bulbs are found the most ideal to analyse power consumption of the Satellite load, since they don't have a reactive component resulting to a pure sinusoidal output. Figure 5 illustrates this analysis connection.

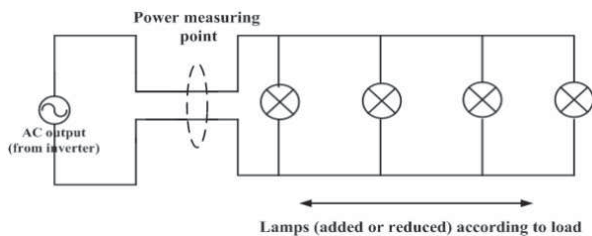

Figure 5: The mode of loading power drop

5. Logging and data taking

Measurement and logging is done to determine the

capability of the PV system to power the Ground Station. The battery and the PV voltage are noted at the start and the end of the logging in period. The following is an illustration of successful logging in and the ultimate RMS value of voltage and current. This was repeated in consecutive days to come up with a good sample.

5.1 Data taken on 27/05/2012

On this date, the measurements for RMS values of current and voltage at 60W and 160W loads were determined. This was followed by logging in for one hour to analyse the variation of voltage and current with time. Table 7 indicates a summary of the measurements done on this date.

5.2 Data of 28/05/2012

On this date, it was possible to log in a 260W load, followed by a 300W load for a total of one hour. Table 8 indicates measurements of RMS of voltage, current and frequency at the start of the analysis followed by variation of these parameters during logging in period

Table 7: Summary for the loads analysed

LOAD 60W	V_{rms}	V_{min}	V_{max}	I_{rms}	I_{min}	I_{max}	F_e	Min	Max
V/A/Hz	122.3	0.1	125.7	5.07	4.91	5.42	50	0	50.1
$V_{rms} \times I_{rms}$	P_{rms}	P_{min}	P_{max}						
Power (W)	620	0.491	681.3						
Logging	122.4	121.1	122.7	5.22	4.97	5.36			
Power (W)	638.9	594.6	657.7						
LOAD160W	120.6	120.1	122.1	5.13	4.80	5.38	50	49.9	50
Power (W)	653.9	624.2	673						
Logging	125.5	124.5	125.6	5.21	4.99	5.45			
Power (W)	653.9	621.3	684.5						

Table 8: Summary for the loads analysed

LOAD 260W	V_{rms}	V_{min}	V_{max}	I_{rms}	I_{min}	I_{max}	F_{req}	Min	Max
V/A/Hz	122.5	0.1	122.8	5.19	4.99	5.45	49.9	0	50.04
$V_{rms} \times I_{rms}$	P_{rms}	P_{min}	P_{max}						
Power	635.8	0.499	669.3						
Logging	122.1	121.1	122.3	5.21	4.96	5.33			
Power	636.1	624.6	657.7						
LOAD									
300W	125.1	125.1	125.1	5.24	499	5.38	49.9	49.9	50
Power	653.9	624.2	673						
Logging	125.5	124.5	125.6	5.21	4.99	5.34			
Power	653.9	621.3	670.7						

5.3 Data of 29/05/2012

A 300W load was successfully logged this date. Table 9 indicates the RMS of voltage, current and frequency. This is followed by variation of these parameters with time during one hour logging in and the resultant PV system power.

Table 9: Summary for the loads analysed

Load 300W	V_{rms}	V_{min}	V_{max}	I_{rms}	I_{min}
V/A/Hz	119.5	0.1	120.5	5.11	4.91
Power (W)	610.6	0.491	650.7		
Logging (36min)	115.7	115.7	116.4	5.33	4.95
Power (W)	616.7	577.7	625.1		

5.4 Data of 30/05/2012: NO LOAD condition

On this date, the PV power system portrayed output characteristics as indicated in Table 10, which includes RMS voltage of 0.1V and a resultant average output RMS power of 0.555W. This implies that the PV power system is unable to power the ground station.

Table10: PV system NO LOAD characteristics

LOAD 160W	V_{rms}	V_{min}	V_{max}	I_{rms}	I_{min}	I_{max}	F_{req}	min	max
V/A/Hz	112.0	112.0	122.1	5.12	4.96	5.32	50	50	50
$V_{rms} \times I_{rms}$	P_{rms}	P_{min}	P_{max}						
Power (W)	573.4	555.5	625.1						
Logging	0.1	0.1	0.1	5.33	4.95	5.37			
Power (W)	0.555	0.495	0.535						

Table 12: Summary current and voltage variation

Time	Voltage variation		Time	Current variation	
	Normal period(RMS)			Max(A)	Min(A)
2:21.12PM	122.087V		2:21.56PM	5.4164A	5.1586 A
2:30.15PM	108.3043V		2:37.25 PM	5.3461 A	5.1 A
2:44.05PM	108.609V		2:44.46 PM	5.2484 A	5.1195 A
2:56.32PM	107.083V		2:56.27 PM	5.2641 A	5.1117 A

Table 11: Dates with NO LOAD conditions

Date	Load	PV Power	Condition
30/04/2012	160W	0.535W	No Load
02/05/2012	100W	0.495W	No Load
06/05/2012	100W	0.495W	No Load
03/05/2012	100W	0.495W	No Load

6. Time plot for 360w load (05/05/2012)

The time plots are done to reveal the quality of the voltage and current supplied by the PV system during access time of the satellite. Figure 6 shows the voltage and current variations plotted against time for a load of 360W for the duration of 36 minutes. This load represents all the functions of the ground station. The study is to establish the capability to power the ground station and the quality of the voltage and current during its operation. Table 12 is the summary, while Table 13 represents the equivalent power variation during the logging in time.

6.1 Time plot for 400W loads (07/05/2012)

Figure 7 shows the voltage and current plotted against time for a load of 400W for duration of 36 minutes. The voltage drops with time while current

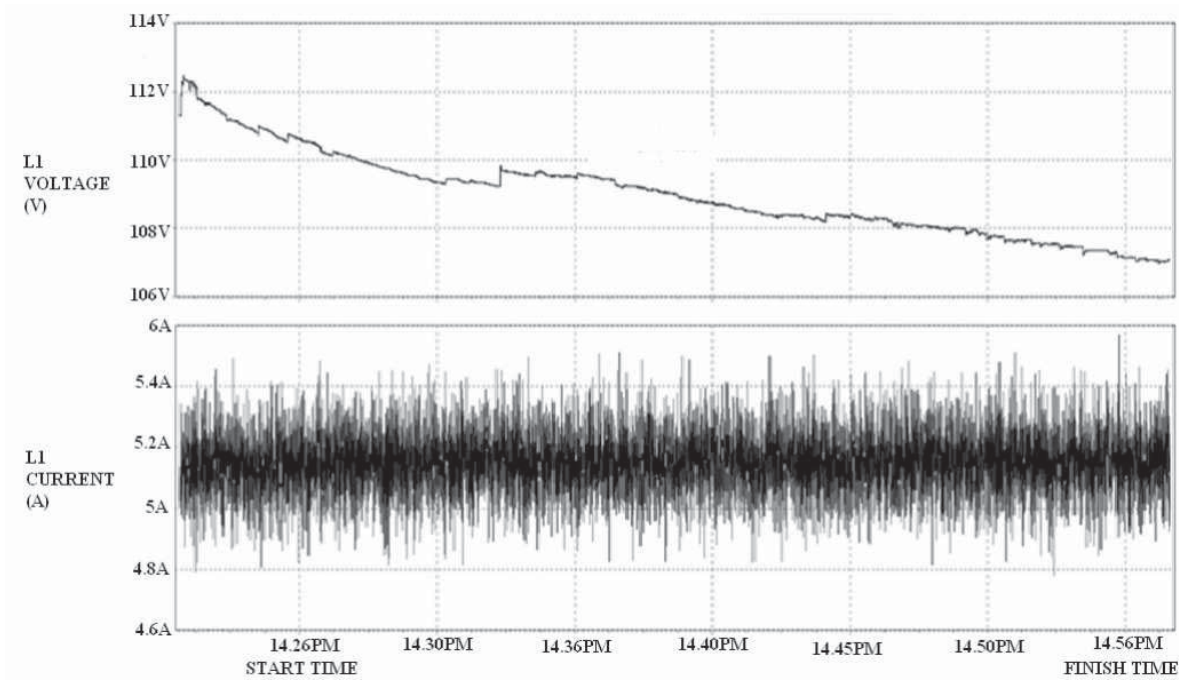

Figure 6: Voltage and current time plot for 360 W load

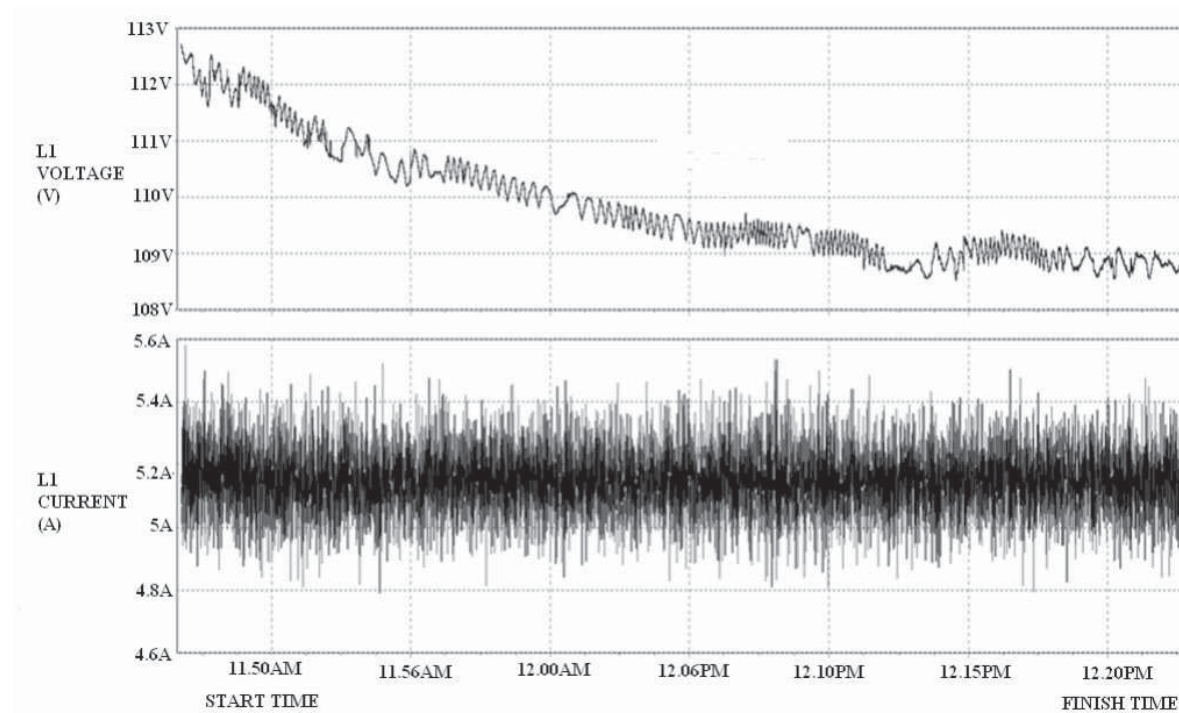

Figure 7: Voltage and current time plot for 400 W load

remains a constant plot. Table 14 is the summary of the variation with time and Table 15 is the equivalent variation of power with time for duration this time when tracking and downloading of data is in progress.

6.2 Summary of the measurements done

The parameters of the PV system monitored against the Ground station equivalent load are illustrated in Table 16.

7. Solar insolation considerations

Solar irradiance is the amount of sunshine received at any time during the day, while solar insolation is the amount of irradiance measured in the day. Solar irradiance varies throughout the day due to movement of the sun and cloud cover. In order to reach a conclusion on the reliability of the designed PV system, solar insolation and cloud cover must be taken into account.

Table 13: Equivalent power variation

Load = 360W $P = V_{RMS} \times I_{RMS}$		
Time duration	Power (max)	Power (min)
2:21.12PM	661.2W	629.8W
2:30.15PM	579W	552.4W
2:44.05PM	570W	556W
2:56.32PM	563.7W	547.4W

Table 14: Summary current and voltage variation

Load = 400W $P = V_{RMS} \times I_{RMS}$		
Time duration	Power (max)	Power (min)
11:47.04AM	662.8W	631.2W
11:59.22AM	577.4W	564W
12:13.07PM	573.1W	554W
12:22.07PM	563.6W	556.4W

7.1 Solar insolation and cloud cover

Solar insolation which is the average solar irradiation received in a day is measured in W/m^2 . On a very clear day, the irradiance reaching the earth surface, facing the sun is $1000W/m^2$ (A.M1.5). From the data of Table 17, this is rearranged as in Table 18, which indicates percentage suns presence and the solar insolation level of the days the data was collected. From this table, solar insolation was only possible with a cloud cover of over 50%.

Table 17: Percentage cloud cover and solar insolation

Date	Temperature range (C)	% sun presence (without clouds)	Solar insolation
27/04/2012	11 ⁰ - 18 ⁰	30%	40W/m ²
28/04/2012	12 ⁰ - 19 ⁰	56%	60W/m ²
29/04/2012	13 ⁰ - 18 ⁰	63%	80W/m ²
30/04/2012	14 ⁰ - 19 ⁰	20%	22.7W/m ²
2/05/2012	13 ⁰ - 19 ⁰	40%	12W/m ²
3/05/2012	12 ⁰ - 18 ⁰	40%	12.2W/m ²
4/05/2012	12 ⁰ - 18 ⁰	35%	45.6W/m ²
5/05/2012	12 ⁰ - 21 ⁰	65%	75.6W/m ²
6/05/2012	13 ⁰ - 20 ⁰	50%	12.2W/m ²
7/05/2012	13 ⁰ - 20 ⁰	65%	89.6W/m ²

8. Results and analysis

8.1 Insolation PV voltage and battery

For insolation level of over $50W/m^2$, the PV voltage ranged between 14.83V to 13.1V on no load and 14.3 to 12.2V on load, while the battery voltage varied between 13.95 and 12.1 on no load and 13.06 to 11.8 on load. This shows solar insolation level and the cloud cover had a direct impact on PV and battery output.

8.2 Insolation, PV voltage and the load

From Table 19, it can be deduced that, for the insolation level of over $40W/m^2$, the PV AC voltage var-

Table 15: Equivalent power variation

Voltage variation		Current variation		
Time	Normal period (RMS)	Time	Max (A)	Min (A)
11:47.04AM	122.5435V	11:47.33AM	5.4086A	5.1508 A
11:59.22 AM	110.2609V	11:58.26 AM	5.2367 A	5.1156 A
12:13.07PM	108.8696V	12:12.18 PM	5.2641 A	5.0688 A
12:22.14PM	108.8478V	12:22.32 PM	5.1781 A	5.1117 A

Table 16: PV parameters and load analysed

Date	PV voltage		Battery voltage (V)		Charging current(A)		AC output V	Max load (W)
	Start	Finish	Start	Finish	Start	Finish		
27/04/12	12.9V	12.V	12.3	11.9V	1.49A	-0.03	226.7	160W
28/04/12	13.6V	12.6V	12.1	11.8V	4.36A	1.6	230V	300W
29/04/12	13.1V	11.9V	12.1	11.1V	1.24A	0.5	226.7	300W
30/04/12	12.3V	11.8V	11.	11.1V	0.65A	-0.03	220.	160W
2/05/12	12.47V	10.47V	12.2	10.74V	0.52A	-0.03	225.3	100W
3/05/12	11.83V	11.6V	11.71	11.2V	0.48A	-0.01	224.6	100W
4/05/12	12.4V	12.20V	12.1	12.0V	0.34A	0.01	228.6	260W
5/05/12	14.31V	13.54V	13.02	12.44V	5.10A	4.30	229.8	360W
6/05/12	12.3V	10.06V	11.8	11.3V	0.32A	-0.01	223	100W
7/05/12	14.88V	14.33V	13.95	13.6V	4.41A	2.0	229.	400W

Table 18: Solar insolation, PV system and battery

Date	% sun presence (without clouds)	Solar insolation	PV voltage		Battery voltage	
			Start	Finish	Start	Finish
27/04/12	30%	40W/m ²	12.9V	12.V	12.3V	11.9V
28/04/12	56%	60W/m ²	13.6V	12.6V	12.1V	11.8V
29/04/12	63%	80W/m ²	13.1V	11.9V	12.1V	11.1V
30/04/12	20%	22.7W/m ²	12.3V	11.8V	11.6V	11.1V
2/05/12	40%	12W/m ²	12.47V	10.47V	12.26V	10.74V
3/05/12	40%	12.2W/m ²	11.83V	11.6V	11.71V	11.2V
4/05/12	35%	45.6W/m ²	12.4V	12.20V	12.12V	12.0V
5/05/12	65%	75.6W/m ²	14.31V	13.54V	13.02V	12.44V
6/05/12	50%	12.2W/m ²	12.3V	10.06VV	11.8V	11.3V
7/05/12	65%	89.6W/m ²	14.88V	14.33V	13.95V	13.06V

Table 19: Solar insolation, PV voltage and load

Date	% sun presence (without clouds)	Solar insolation	AC output	Max load (W)
27/04/12	30%	40W/m ²	226.7V	160W
28/04/12	56%	60W/m ²	230V	300W
29/04/12	63%	80W/m ²	226.7V	300W
30/04/12	20%	22.7W/m ²	220.V	160W
2/05/12	40%	12W/m ²	225.3V	100W
3/05/12	40%	12.2W/m ²	224.6V	100W
4/05/12	35%	45.6W/m ²	228.6V	260W
5/05/12	65%	75.6W/m ²	229.8V	360W
6/05/12	50%	12.2W/m ²	223V	100W
7/05/12	65%	89.6W/m ²	229.8V	400W

Table 20: Solar insolation, power, and ground station

Date	% sun presence (without clouds)	Solar insolation	Max load (W)	PV power (max)	Ground station function
27/04/12	30%	40W/m ²	160W	674.5W	PC+ communication
28/04/12	56%	60W/m ²	300W	670.7W	Azmuth+ rotator + communication
29/04/12	63%	80W/m ²	300W	625.1W	Azmuth+ rotator + communication
30/04/12	20%	22.7W/m ²	160W	0.545W	PC (no load)
2/05/12	40%	12W/m ²	100W	0.495W	PC (no load)
3/05/12	40%	12.2W/m ²	100W	0.495W	PC (no load)
4/05/12	35%	45.6W/m ²	260W	669.3W	Azmuth+ rotator + communication
5/05/12	65%	75.6W/m ²	360W	661.2W	Azmuth + rotator + communication
6/05/12	50%	12.2W/m ²	100W	0.495W	PC (no load)
7/05/12	65%	89.6W/m ²	400W	662.8W	Azmuth+ rotator + communication

ied between 226.7VAC and 229.8VAC. Full Ground Station operation (over 260W) was only possible with over 45W/m² insolation level. Thus solar insolation level had a direct impact on AC voltage and Ground Station Load.

8.3 Insolation, power and ground station function

Table 20 illustrates the relationship between solar irradiation, maximum load, PV system maximum power and the ground station function. The

Maximum PV power varied from 684.5W to 661.2W. For all the functions of the Ground Station to be attained solar insolation should be at least 45W/m². The success of the system depends on proper design of its components, the cloud cover and solar insolation level.

9. Conclusions and recommendations

A hallmark of this research is that with solar irradiation as low as 50W/m² the designed PV system can successfully power the ground station for one hour continuously, which involves satellite tracking and downloading of data. The PV panels were designed to operate at an irradiance of 800W/m². The power budget of the satellite ground station is at a maximum at 567W, while the PV designed system is capable of a maximum power ranging from 684.5W and 554W. From the logged data, the current remains almost constant with time, while voltage falls. It's found that if the battery is at a low of 10.9V, this is a NO LOAD condition.

- The system is expected to operate with over 90% efficiency and reliability in the Free State, North West, Limpopo, interior parts of the Western and Eastern Cape and parts of Africa where solar insolation levels are over 100W/m².
- For locations with lower insolation levels, larger solar PV panels are recommended.
- This methodology is recommended for any load, to reduce power wastage, cost and improve on system reliability and the availability of load in PV standalone systems.

References

- Beshr, H.M *et al.* 2010. *Modelling of a Residential Solar Standalone Power System*. Proceeding of the 1st International Nuclear and Renewable Energy conference (10).
- Bhandari, R and Stadler, I (2011). Electrification using Solar Photovoltaic Systems in Nepal. *Applied Energy Journal* 88:458-465.
- Duffa, J. A & Beckmann. A. (2004). *Solar Engineering of Thermal process*.
- ECOFYS, (2005). *Planning and Installing Photovoltaic Systems*. A guide for installers, architects and Engineers. The German Solar Society (DGS LV Berlin, BRB).
- Gevorkian, P. (2008). *Solar Power in Building Design*. The engineers complete design resource. UK: McGraw-Hill.
- Hassan, A.A *et al* (2010). *The Standalone PV Generation System for an Engineering Health Clinic*. International Conference on Renewable Energies and Power Quality (10).
- Kaldelis, J.K., Zafirakis, D and Kondili, E (2010). Energy payback period analysis of Standalone Photovoltaic Systems. *Renewable energy Journal* 35:1444-1454.
- Kirtikira, K. (2004). *Lesson Learnt from using PV Standalone Systems to provide a better quality of life to rural people*. *Acia Astronomical Journal* (46)6:213-220.

- Manju, B *et al.*, (2011). *Design and Modelling of Standalone Solar Photovoltaic Charging System*. *International Journal of Computer Application* (2) 18
- Markvart, T. (2008). *Solar Electricity*. New York: Wiley InterScience.
- Nafeh A, E. (2009). Design and Economic Analysis of Standalone PV system to Electrify a Remote Area House hold in Egypt. *The Open Renewable Energy Journal* (2)33-37
- Wang, H & Zhang, D. (2010). *The Standalone PV Generation System with Parallel Charger*. International Conference on Electrical Engineering.
- Wu, X *et al.*, (2010). *Optimal Design of Structures of PV Array in Photovoltaic Systems*. International Conference on intelligent System Design and Engineering Applications.

Received 7 October 2012; revised 24 May 2014