

An analysis of a thermal power plant working on a Rankine cycle: A theoretical investigation

R K Kapooria

Department of Mechanical Engineering, BRCM College of Engineering & Technology, Bahal (Haryana) and National Institute of Technology, Kurukshetra, India

S Kumar

Department of Mechanical Engineering, National Institute of Technology Kurukshetra, India

K S Kasana

Department of Mechanical Engineering, National Institute of Technology, Kurukshetra, India

Abstract

Today, most of the electricity produced throughout the world is from steam power plants. However, electricity is being produced by some other power generation sources such as hydropower, gas power, bio-gas power, solar cells, etc. One newly developed method of electricity generation is the Magneto hydro dynamic power plant. This paper deals with steam cycles used in power plants. Thermodynamic analysis of the Rankine cycle has been undertaken to enhance the efficiency and reliability of steam power plants. The thermodynamic deviations resulting in non-ideal or irreversible functioning of various steam power plant components have been identified. A comparative study between the Carnot cycle and Rankine cycle efficiency has been analyzed resulting in the introduction of regeneration in the Rankine cycle. Factors affecting efficiency of the Rankine cycle have been identified and analyzed for improved working of thermal power plants.

Keywords: Rankine cycle, steam-turbine, efficiency, Feed Water Heater (FWH), irreversibility, reheat cycle, regeneration, condensers

Introduction: Rankine and Carnot cycle

The Rankine cycle is a heat engine with a vapour power cycle. The common working fluid is water. The cycle consists of four processes as shown in Figures 1 (a) and 1 (b):

1 to 2: Isentropic expansion (Steam turbine) An isentropic process, in which the entropy of working fluid remains constant.

2 to 3: Isobaric heat rejection (Condenser) An iso-

baric process, in which the pressure of working fluid remains constant.

3 to 4: Isentropic compression (Pump) During the isentropic compression process, external work is done on the working fluid by means of pumping operation.

4 to 1: Isobaric heat supply (Steam Generator or Boiler) During this process, the heat from the high temperature source is added to the working fluid to convert it into superheated steam.

According to the T-s diagram shown in Figure 1(b), the work output W_1 during isentropic expansion of steam in the turbine, and the work input W_2 during isentropic compression of working fluid in the pump are:

$$W_1 = m (h_1 - h_2) \quad (1.1)$$

and

$$W_2 = m (h_4 - h_3) \quad (1.2)$$

Where m is the mass flow of the cycle and h_1, h_2, h_3, h_4 is enthalpy. Heat supplied to the cycle (steam generator or boiler) Q_1 , and heat rejected from the cycle (condenser) Q_2 , are:

$$Q_1 = m (h_1 - h_4) \quad (1.3)$$

and

$$Q_2 = m (h_2 - h_3) \quad (1.4)$$

The net work output of the cycle is:

$$W = W_1 - W_2 \quad (1.5)$$

The efficiency of the Rankine cycle is:

$$\eta = W/Q_1 \quad (1.6)$$

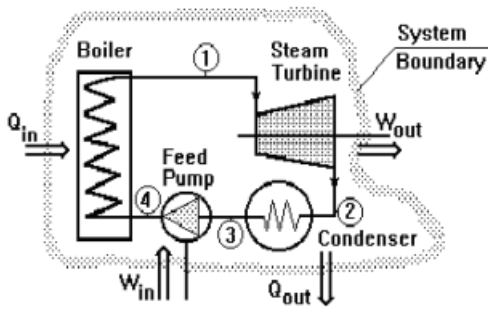

Figure 1a

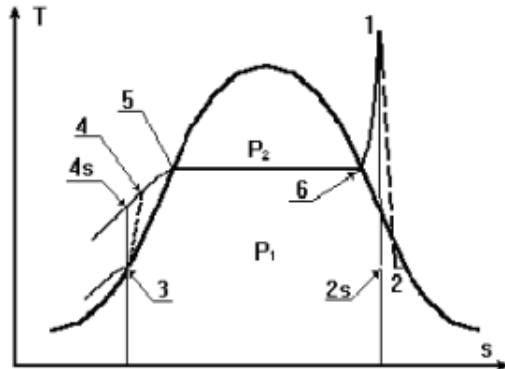

Figure 1b: T-s diagram for a Rankine cycle
Source: Taftan Data

The thermal efficiency of a Rankine cycle is not as high as a Carnot cycle but the cycle has less practical difficulties and is found to be more economical. Thermodynamically, it is true that no heat engine can be more efficient than a reversible heat engine working between two fixed temperature limits.

A Carnot cycle consists of the following processes as shown in Figure 2. These processes are theoretical because these cannot be achieved practically due to certain limitations. A brief discussion of these processes is discussed below. Theoretically, the Carnot cycle is the most efficient heat energy conversion cycle.

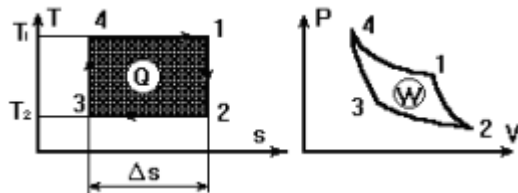

Figure 2: T-s and P-V diagrams for Carnot cycle
Source: Taftan Data

1 to 2: Isentropic expansion, 2 to 3: Isothermal heat rejection, 3 to 4: Isentropic compression
4 to 1: Isothermal heat supply

The heat supplied to the cycle per unit mass flow, $Q_1 = T_1 ds$, and the heat rejected from the cycle per unit mass flow, $Q_2 = T_2 ds$.

By applying the first law of thermodynamics to the cycle, we obtain:

$$Q_1 - Q_2 - W = 0 \quad (1.7)$$

And the thermal efficiency of the cycle will be:

$$\eta = W/Q_1 = 1 - T_2/T_1 \quad (1.8)$$

Due to mechanical friction and other irreversibility's, no cycle can achieve this efficiency. The gross work output of the cycle, i.e. the work done by the system is:

$$W_g = W_{4-1} + W_{1-2} \quad (1.9)$$

And the work ratio is defined as the ratio of the net work W to the gross work output W_g , i.e. W/W_g .

The Carnot cycle has a low work ratio. Although, theoretically, this cycle is the most efficient system for power generation, it cannot be used in practice. There are several reasons such as a low work ratio, economical aspects and practical difficulties. Some recent developments to enhance the efficiency of the Rankine cycle have been analyzed.

Thermal power plant based on a Rankine cycle

In a simple Rankine cycle, steam is used as the working fluid, generated from saturated liquid water (feed-water). This saturated steam flows through the turbine, where its internal energy is converted into mechanical work to run an electricity generating system. All the energy from steam cannot be utilized for running the generating system because of losses due to friction, viscosity, bend-on-blade etc. Most of the heat energy is rejected in the steam condenser. The feed water brings the condensed water back to the boiler.

The heat rejected during condensation of steam in the condenser is given away by a sink. As a result of the conversion of much of its thermal energy into mechanical energy, or work, steam leaves the turbine at a pressure and temperature well below the turbine entrance values. Basically the low- pressure steam leaving the turbine at state 2 is first condensed to a liquid at state 3 and then pressurized in a pump to state 4, and this high pressure liquid water is then ready for its next pass through the steam generator to state 1 and is reused around the Rankine cycle again as shown in Figure 3.

The steam generator and condenser both function as heat exchangers. In a well-designed heat exchanger, both hot and cold fluids flow with little pressure loss. Therefore, ideally it can be considered that steam generators and condensers have negligible pressure loss, where fluids are operating without any change in pressure. Hence, the Rankine cycle is operating between two fixed pressure levels, i.e. the pressure in the steam generator and pressure in the

condenser. A pump provides the pressure increase, and a turbine provides the controlled pressure drop between these levels. The Rankine cycle as a system (Figure 3) converts thermal energy of the steam into mechanical energy by means of a turbine rotation, which runs the generator to produce electrical energy.

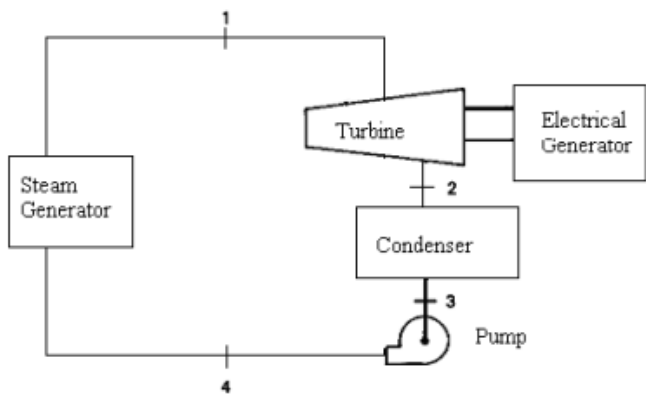

Figure 3: Rankine-cycle and T-s diagrams

Rankine cycle analysis

In the analysis of a heat engine cycle, it is assumed that the fluid flow follows the continuity equation applicable to steady state conditions. All the power plants are assumed to run under steady state conditions. The starting and shutting down working condition is exempted where deviations from a steady state cannot be avoided. With reference to the Rankine cycle shown in Figure 3, the control of the flow can be exercised by a valve. Partial closer of the valve would reduce the flow of steam in the turbine and power output. In the ideal Rankine cycle, working fluid follows reversible an adiabatic or isentropic path in the turbine and is subjected to lower pressure and temperature in the condenser.

Applying the First Law of Thermodynamics for an isentropic turbine:

$$q = 0 = h_2 - h_1 + w_t \text{ [kJ/kg]} \quad (2.1)$$

where kinetic and potential energy differences between the inlet and outlet are negligibly small. The above equation shows that the turbine work per unit mass passing through the turbine is the difference between the entrance enthalpy and exit enthalpy,

$$w_t = h_1 - h_2 \text{ [kJ/kg]} \quad (2.2)$$

The power delivered by the turbine to an external load, such as an electrical generator, is given as,

$$\text{Turbine power} = m_s w_t = m_s (h_1 - h_2) \text{ [kW]} \quad (2.3)$$

Applying the steady-flow First Law of Thermodynamics to the steam generator, shaft work is zero

and the steam generator heat transfer is given by the equation;

$$q_a = h_1 - h_4 \text{ [kJ/kg]} \quad (2.4)$$

The condenser is a large shell-and-tube type heat exchanger. This is positioned next to the turbine in order to receive a large flow rate of low pressure steam. This steam in the condenser goes under a phase change from vapour to liquid water. External cooling water is pumped through thousands of tubes in the condenser to transport the heat of condensation of the steam away from the plant. Upon leaving the condenser, the condensate is at a low temperature and pressure. Removal of this condensate may be considered as maintaining the low pressure in the condenser continuously. The phase change in turn depends on the transfer of heat to the external cooling water. The rejection of heat to the surroundings by the cooling water is essential to maintain the low pressure in the condenser. Applying the steady-flow First Law of Thermodynamics to the condensing steam enables:

$$q_c = h_3 - h_2 \text{ [kJ/kg]} \quad (2.5)$$

The value of q_c is negative because $h_2 > h_3$. Thus, consistent with sign convention, q_c represents an outflow of heat from the condensing steam. This heat is absorbed by the cooling water passing through the condenser tubes. The rise in cooling-water temperature and mass-flow rate m_c are related to the rejected heat by the following equation,

$$m_s |q_c| = m_c c_{\text{water}} (T_{\text{out}} - T_{\text{in}}) \text{ [kW]} \quad (2.6)$$

Where c_{water} is the heat capacity of the cooling water [kJ/kg-K]. The condenser cooling water may be drawn from a river or a lake at a lower temperature and returned downstream at a higher temperature. Alternatively, it may be circulated through cooling towers where heat is rejected from the cooling water to the atmosphere. The condenser heat transfer can be expressed in terms of an overall heat transfer coefficient, U , the mean cooling water temperature, $T_m = (T_{\text{out}} + T_{\text{in}}) / 2$, and the condensing temperature T_3 by the following equation;

$$m_s |q_c| = UA (T_3 - T_m) \text{ [kJ/s]} \quad (2.7)$$

For a given heat rejection rate, the condenser size is represented by the tube surface area A that depends inversely on (a) the temperature difference between the condensing steam and the cooling water, and (b) the overall heat-transfer coefficient U . For a fixed average temperature difference between the two fluids on opposite sides of the condenser tube walls, the temperature of the available cooling water controls the condensing temperature

and hence, the pressure of the condensing steam. Therefore, the colder the cooling water, the lower is the temperature and pressure of the cycle and the higher is the thermal efficiency of the cycle. A pump is a device that moves liquid from a low pressure to high pressure. In the Rankine cycle, the condensate is raised to the pressure of the steam generator by boiler-feed-pumps (BFP). The high-pressure liquid water entering the steam generator is called feed-water. From the steady-flow First Law of Thermodynamics, the work and power required to drive the pump are given by the equations,

$$\text{Work, } w_p = h_3 - h_4 \text{ [kJ/kg]} \quad (2.8)$$

and,

$$\text{Pump power} = m_s w_p = m_s (h_3 - h_4) \text{ [kW]} \quad (2.9)$$

The pump work has a negative value as $h_4 > h_3$. This is consistent with the thermodynamic sign convention, which indicates that work and power must be supplied to operate the pump. The net power delivered by the Rankine cycle is the difference between the turbine power and the magnitude of the pump power.

One of the significant advantages of the Rankine cycle is that the pump power is usually quite small compared with the turbine power. This is indicated by the work ratio, w_t / w_p , which is large compared with one for the Rankine cycle. As a result, the pumping power is neglected in approximating the Rankine cycle net power output. It is assumed that the liquid at a pump entrance is saturated liquid because the condensate temperature never reaches below exit cooling water temperature. That is usually the case for power-plant feed-water pumps.

Sub cooling would increase the heat input in the steam generator, and on the other hand, the introduction of steam into the pump would cause poor performance. The properties of the pump inlet or condenser exit (state 3 in Figure 3) therefore, may be obtained directly from the saturated-liquid curve at the (usually) known condenser pressure. The properties for an isentropic pump discharge at state 4 could be obtained from a sub cooled-water property table at the known inlet entropy and the throttle pressure. However, such tables are not widely available. The enthalpy of a sub cooled state is commonly approximated by the enthalpy of the saturated-liquid evaluated at the temperature of the sub cooled liquid. This is usually quite accurate because the enthalpy of a liquid is almost independent of pressure as the Rankine cycle based thermal power plant works at atmospheric pressure.

A measure of the effectiveness of an energy conversion device is its thermal efficiency. This is defined as the ratio of the cycle network to the heat supplied from external sources. Thus, by using the above equations (2.2, 2.4, and 2.6) the ideal Rankine-cycle thermal efficiency in terms of cycle

enthalpies is given as:

$$\eta = (h_1 - h_2 + h_3 - h_4) / (h_1 - h_4) \quad (3.1)$$

In accordance with the Second Law of Thermodynamics, the Rankine cycle efficiency must be less than the efficiency of a Carnot engine operating between the same temperature extremes. As with the Carnot-cycle efficiency, Rankine-cycle efficiency improves when the average heat-addition temperature increases and the heat rejection temperature decreases. The cycle efficiency may be improved by increasing turbine inlet temperature and decreasing the condenser pressure (and thus the condenser temperature).

Another practical aspect affecting the efficiency is the heat rate. Heat rate is the ratio of the rate of heat addition in conventional heat units (boiler) to the net power output in conventional power units (turbine). Because the rate of heat addition is proportional to the fuel consumption rate, the heat rate is a measure of fuel utilization rate per unit of power output. In the United States, the rate of heat addition is usually stated in Btu/hr, and electrical power output in kilowatts, resulting in heat rates being expressed in kW-hr. It may be verified that the heat rate in English units is given by the conversion factor, 3413 kW-hr, divided by the cycle thermal efficiency as a decimal fraction, and that its value has a magnitude of the order of 10 000 kW-hr. In SI system of units, the heat rate is usually expressed in kJ/kW-hr, is given by 3600 divided by the cycle efficiency as a decimal fraction, and is of the same order of magnitude as in the English system. The low value of heat rate represents high thermal efficiency and is of course desirable.

Power plant deviations and component efficiencies

The study of a thermal power plant reveals the eddy turbulence, fluid friction, and pressure/temperature dependent viscosity variations of working fluid, which are not considered under ideal conditions. Decisions regarding the analysis and technological advancements for these effects become vital while looking for the improvement of the efficiency of thermal power plants. Turbine, steam generator (boiler) and a pump are the basic components of a steam thermal power plant. An analytical discussion about the steam turbine and pump functions has been taken up as these affect the Rankine cycle efficiency.

Steam turbine

The adiabatic steam turbine with irreversible flow exhibits the same thermodynamic results as in the case of an isentropic turbine shown in the equation below;

$$W_t = h_1 - h_2 \text{ [kJ/kg]} \quad (2.2)$$

Here h_2 represents the actual exit enthalpy and w_t is the actual work of an adiabatic turbine where all the above discussed non-ideal irreversible components working under non-ideal conditions that exist. The efficiency of a real turbine, known as isentropic efficiency, is defined as the ratio of the actual shaft work to the shaft work for an isentropic expansion between the same inlet and exit pressure (Figure 4).

The turbine efficiency is:

$$\eta_{\text{turb}} = (h_1 - h_2) / (h_1 - h_{2s}) \quad (2.8)$$

where h_{2s} is enthalpy evaluated at the turbine inlet entropy and at the exit pressure.

Under ideal conditions, $h_2 = h_{2s}$ - the efficiency becomes 1. In Figure 4, points 2 and 2 represent work lost due to irreversibility.

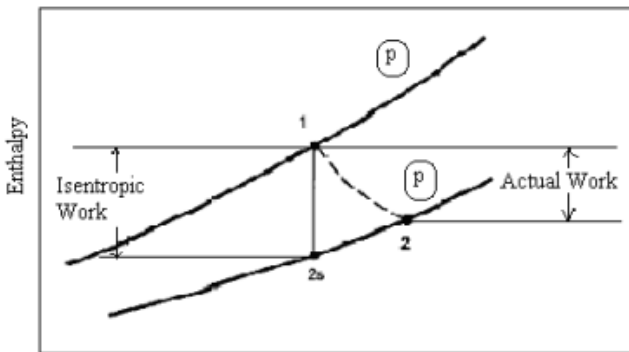

Figure 4: Turbine efficiency

Pump

The turbine condensate is recycled by using a pressure centrifugal pump. External work must be supplied to a pump to move liquid from a low pressure to a high pressure. The sensible internal energy of the liquid water is enhanced by means of doing work through pumping, however, considerable work energy is lost due to irreversibility. Therefore, the remaining effective work to raise the pressure is less than supplied. Pump efficiency is the ratio of the isentropic work to the actual work input when operating between two given pressures. Applying equation (2.4) and the notation of Figure 5, the isentropic pump work, $w_{ps} = h_3 - h_{4s}$, and the pump isentropic efficiency is;

$$\eta_{\text{pump}} = w_{ps} / w_p = (h_{4s} - h_3) / (h_4 - h_3) \quad (2.9)$$

With reference to Figure 5, it would seem that the pump lost work, given by $h_4 - h_{4s}$ decreases and that the actual discharged state approaches the isentropic discharge state. States 4 and 4s are usually sub-cooled liquid states and as a first approximation their enthalpies may be taken to be the saturated liquid enthalpy at T_3 .

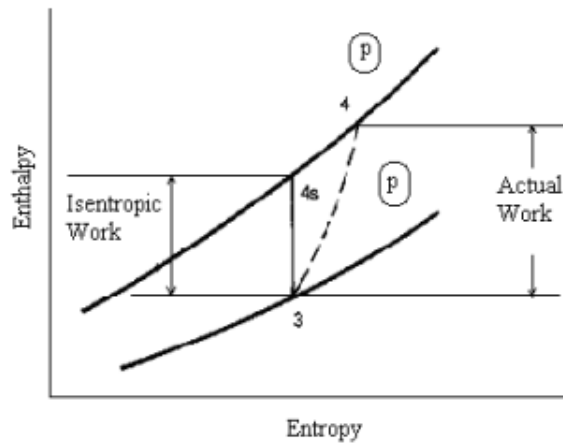

Figure 5: Pump efficiency

More accurate approximations for these enthalpies may be obtained by applying the First Law for a closed system undergoing a reversible process, equation: $Tds = dh - vdp$. For an isentropic process, it follows that $dh = vdp$ as $ds = 0$. Because a liquid is almost incompressible, its specific volume, v , is almost independent of pressure. Thus, using the notation of Figure 5 for $dh = vdp$ where, $dh = h_{4s} - h_3$, and $dp = p_4 - p_3$. This equation on integration with respect to constant specific volume gives $h_{4s} = h_3 + v_3 (p_4 - p_3)$ [kJ/kg], where the knowledge of State 3 and p_4 determines h_{4s} . Using Equation (2.9), pump work can be calculated for a given efficiency of the pump.

Reheat cycles

The Rankine cycle has been modified to produce more output work by introducing two stage steam turbines, using intermediate heating. Basically, in this modified Rankine cycle, the full expansion of steam is interrupted in the high-pressure turbine and steam is discharged after partial expansion. This exhaust steam is passed through a cold reheat line to the steam generator where it gains heat while passing through hot tubes. This reheated steam is supplied to a low pressure turbine for full expansion and reaches the condenser pressure. The modified Rankine T-S diagram shows some increase in the area which is attained because of the introduction of the reheating of steam. This results in low pressure turbine expansion work. Thus, reheat increases work output because of low pressure turbine expansion work.

The use of reheat also tends to increase the average temperature at which heat is added. If the steam from the low-pressure turbine is superheated, the use of reheat may also increase the average temperature at which heat is rejected. It may reduce or increase the thermal efficiency depending on the specific cycle conditions viz. thermal (heat addition and heat rejection temperature) or mechanical (condenser vibrations and air leakage, pump vibrations, turbine blade vane deflection etc). Indeed the

net work of the reheat cycle is the algebraic sum of the work of the two turbines and the pump work and the total heat addition is the sum of the heat added in the feed-water and reheat passes through the steam generator. Thus, the thermal efficiency of the reheat cycle is:

$$\eta_{th} = \frac{(h_1 - h_2) + (h_3 - h_4) + (h_5 - h_6)}{(h_1 - h_6) + (h_3 - h_2)} \quad (3.2)$$

Reheat offers the ability to limit or eliminate moisture at the turbine exit. The presence of more than about 10% moisture in the turbine exhaust can cause erosion of blades near the turbine exit and reduce energy conversion efficiency. Figure 6 shows that reheat shifts the turbine expansion process away from the two-phase region and toward the superheat region of the T-s diagram, thus drying the turbine exhaust.

Determination of a suitable reheat pressure level is a significant design problem that entails a number of considerations. The cycle efficiency, the net work, and other parameters will vary with the reheat pressure level for a given throttle and condenser conditions. One of these may be numerically optimized by varying the reheat pressure level while holding all other design conditions constant.

Carnot vs Rankine cycle efficiency analysis

Carnot cycle efficiency is greater than the Rankine cycle because the heat addition and heat rejection of the Carnot cycle takes place at a single high temperature and at a single low temperature. Heat additions in the steam generator of the Rankine cycle takes place over a wide range of water temperatures in both simple and reheat Rankine cycles. The Rankine cycle efficiency could be improved by introducing intermediate reheating of the working fluid (water) before entering the steam generator. This process of reheating is described as 'Regeneration' which uses sensible heat of a small

amount of steam taken from the high pressure turbine.

Basically this enables internal transfer of heat from high temperature steam to low temperature condensate (feed-water). Regeneration is accomplished in all large-scale, modern power plants through the use of feed water heaters. A feed water heater (FWH) is a heat exchanger in which the latent heat (and sometimes superheat) of small amounts of steam is used to increase the temperature of liquid water (feed water) flowing to the steam generator. This provides the internal transfer of heat discussed above. Steam drawn from a turbine for feed-water heating or other purposes is called extraction steam.

The steam leaving the high-pressure (HP) turbine is split with a small part of the mass flow extracted to an open FWH and the major part of the flow passing to a low pressure (LP) turbine. The T-s diagram shows that steam entering the FWH at state 2 is at a higher temperature than the sub-cooled feed water leaving the pump at state 5. When the two fluids mix in the FWH, the superheat and the heat of vaporization of the extraction steam are transferred to the feed water. This emerges with the condensed extraction steam at a higher temperature, T_6 . It is assumed that steam entering and leaving the FWH are at the same pressure so that the mixing process occurs at constant pressure. The T-s and flow diagrams show that heat from combustion gases in the steam generator need only raise the water temperature from T_7 to T_1 rather than from T_5 when extraction steam is used to heat the feed water. The average temperature for external heat addition must therefore increase, despite the reduced flow rate through the low pressure turbine.

Concluding remarks

The technological investigations and analysis of various important characters affecting the thermal power plant's overall efficiency and other related

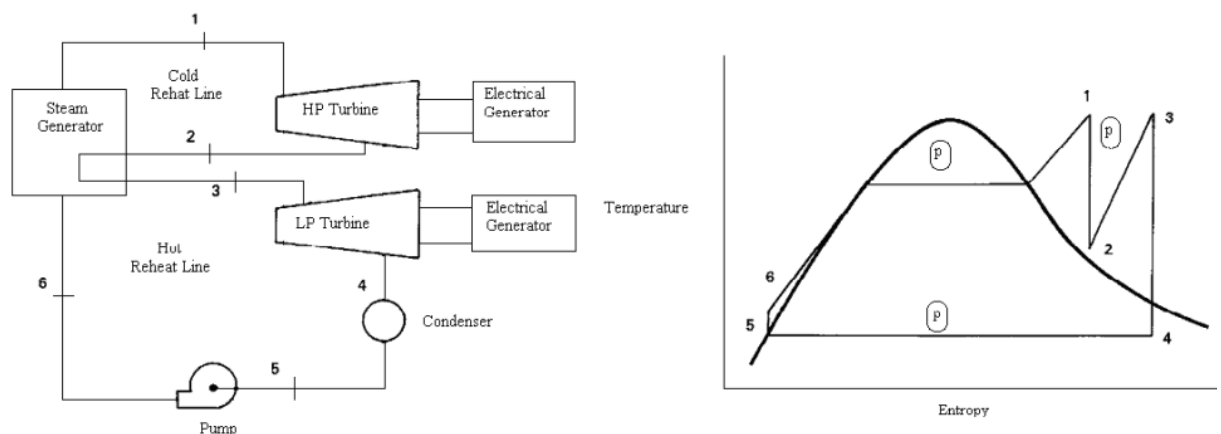

Figure 6: Rankine reheat cycle

factors responsible for deviation from ideal working of the Rankine cycle have been discussed. The efficiency of a simple Rankine cycle is improved by using intermediate reheat cycle, enabling improved thermal conditions of the working fluid. However, it cannot reach the thermal conditions as in the case of the Carnot cycle where heat addition and heat rejection occurs at a specified temperature range. The regeneration is vital to improve the efficiency as it uses the sensible heat of exhaust steam for the preheating of feed water. Inclusion of a FWH also introduces an additional pressure level into the Rankine cycle as seen in the T-s diagram. Hence, the extraction pressure level is another parameter under the control of the designer. The control of steam condenser pressure i.e. condenser vacuum and supply of condenser tube cooling water is another parameter which affects the steam thermal power plant efficiency.

References

- Arora, C.P. (1998), *Thermodynamics*, Tata Mc Graw-Hill, New Delhi.
- Ballaney, P.L. (1999), *Thermal Engineering*. Khanna, Delhi.
- Cengel, Y.A., and Boles, M.A. (2003), *Thermodynamics . An Engineering Approach*, Tata Mc Graw-Hill. New Delhi.
- Drbal, L.F. (1996), *Power Plant Engineering*, Black & Veatch (COR).
- El-Wakil, M. M. (1984), *Power Plant Technology*. New York: McGraw-Hill.
- Fundamentals of Steam Power, www.personal.utulsa.edu/~kenneth-weston/chapter2.pdf.
- Haywood, R.W. (1980), *Analysis of Engineering Cycles*. Pergamon Press.
- Kiameh, P. (2002), *Power Generation Handbook*, McGraw-Hill Handbooks.
- Li, Kam W., and Priddy, A. Paul (1985), *Power plant System Design*. New York: Wiley.
- Moran, M.J. and Shapiro H.N. (2000), *Fundamentals of Engineering Thermodynamics*, John Wiley & Sons (Asia).
- Nag, P.K. (1995), *Engineering Thermodynamics*, Tata Mc Graw-Hill., New Delhi.
- Rajput, R.K. (2001), *Thermal Engineering*, Laxmi, New Delhi.
- Skrotzi, B. G. A. and Vopat, W. A. (1960), *Power Station Engineering and Economy*. New York: McGraw-Hill.
- Whalley, P.B. (1992), *Basic Engineering Thermodynamics*, Oxford University Press..
- Wood, B. (1981), *Applications of Thermodynamics*, 2nd ed. Reading, Mass.: Addison- Wesley.

Received 2 February 2007; 12 September 2007